

Altivar Easy

Variable Speed Drives ATV610

Installation Manual

07/2019



The information provided in this documentation contains general descriptions and/or technical characteristics of the performance of the products contained herein. This documentation is not intended as a substitute for and is not to be used for determining suitability or reliability of these products for specific user applications. It is the duty of any such user or integrator to perform the appropriate and complete risk analysis, evaluation and testing of the products with respect to the relevant specific application or use thereof. Neither Schneider Electric nor any of its affiliates or subsidiaries shall be responsible or liable for misuse of the information contained herein. If you have any suggestions for improvements or amendments or have found errors in this publication, please notify us.

You agree not to reproduce, other than for your own personal, noncommercial use, all or part of this document on any medium whatsoever without permission of Schneider Electric, given in writing. You also agree not to establish any hypertext links to this document or its content. Schneider Electric does not grant any right or license for the personal and noncommercial use of the document or its content, except for a non-exclusive license to consult it on an "as is" basis, at your own risk. All other rights are reserved.

All pertinent state, regional, and local safety regulations must be observed when installing and using this product. For reasons of safety and to help ensure compliance with documented system data, only the manufacturer should perform repairs to components.

When devices are used for applications with technical safety requirements, the relevant instructions must be followed.

Failure to use Schneider Electric software or approved software with our hardware products may result in injury, harm, or improper operating results.

Failure to observe this information can result in injury or equipment damage.

© 2019 Schneider Electric. All rights reserved.

Table of Contents



	Safety Information	5
	About the Book	9
Chapter 1	Introduction	11
	Verifying the Absence of Voltage	12
	Drive Overview	13
	Accessories and Options	16
	Green Premium™	16
	Steps for setting up the drive	17
	Preliminary Instructions	18
Chapter 2	Technical Data	19
2.1	Environment Data	20
	Temperature Conditions	21
	Altitude Conditions	21
	Chemical and Mechanical Conditions	21
2.2	Mechanical Data	22
	Dimensions and Weights	22
2.3	Electrical Data - Drive Ratings	28
	Drive Ratings in Normal Duty	29
	Drive Ratings in Heavy Duty	30
2.4	Electrical Data - Upstream Protective Device	31
	Introduction	32
	Prospective Short-Circuit Current	34
	IEC Type Circuit-Breaker as SCPD	37
	IEC Fuses	38
Chapter 3	Drive Mounting	39
	Mounting Conditions	40
	Derating Curves	44
	Mounting Procedures	47
Chapter 4	Drive wiring	49
	Wiring Instructions	50
	Cable Length Instructions	55
	General Wiring Diagrams	57
	Output Relay with Inductive AC Loads	60
	Output Relay with Inductive DC loads	61
	Sink / Source Switch Configuration	63
	Characteristics of the Power Part Terminals	64
	Wiring The Power Part	67
	Electromagnetic Compatibility	71
	Operation on an IT or Corner Grounded System	73
	Disconnecting The Built-in EMC Filter	74
	Arrangement and Characteristics of Control Block Terminals and Communication and I/O Ports	77
	Control Terminals Electrical Data	78
	Wiring The Control Part	81
Chapter 5	Checking Installation	85
	Check List Before Switching On	85

Chapter 6 Maintenance	87
Scheduled Servicing	87
Long-term Storage	89
Decommissioning	89
Additional Support	89
Glossary	91



Important Information

NOTICE

Read these instructions carefully, and look at the equipment to become familiar with the device before trying to install, operate, service, or maintain it. The following special messages may appear throughout this documentation or on the equipment to warn of potential hazards or to call attention to information that clarifies or simplifies a procedure.



The addition of this symbol to a “Danger” or “Warning” safety label indicates that an electrical hazard exists which will result in personal injury if the instructions are not followed.



This is the safety alert symbol. It is used to alert you to potential personal injury hazards. Obey all safety messages that follow this symbol to avoid possible injury or death.

DANGER

DANGER indicates a hazardous situation which, if not avoided, **will result in** death or serious injury.

WARNING

WARNING indicates a hazardous situation which, if not avoided, **could result in** death or serious injury.

CAUTION

CAUTION indicates a hazardous situation which, if not avoided, **could result in** minor or moderate injury.

NOTICE

NOTICE is used to address practices not related to physical injury.

PLEASE NOTE

Electrical equipment should be installed, operated, serviced, and maintained only by qualified personnel. No responsibility is assumed by Schneider Electric for any consequences arising out of the use of this material.

A qualified person is one who has skills and knowledge related to the construction and operation of electrical equipment and its installation, and has received safety training to recognize and avoid the hazards involved.

Qualification Of Personnel

Only appropriately trained persons who are familiar with and understand the contents of this manual and all other pertinent product documentation are authorized to work on and with this product. In addition, these persons must have received safety training to recognize and avoid hazards involved. These persons must have sufficient technical training, knowledge and experience and be able to foresee and detect potential hazards that may be caused by using the product, by changing the settings and by the mechanical, electrical and electronic equipment of the entire system in which the product is used. All persons working on and with the product must be fully familiar with all applicable standards, directives, and accident prevention regulations when performing such work.

Intended Use

This product is a drive for three-phase asynchronous motors and intended for industrial use according to this manual. The product may only be used in compliance with all applicable safety standard and local regulations and directives, the specified requirements and the technical data. The product must be installed outside the hazardous ATEX zone. Prior to using the product, you must perform a risk assessment in view of the planned application. Based on the results, the appropriate safety measures must be implemented. Since the product is used as a component in an entire system, you must ensure the safety of persons by means of the design of this entire system (for example, machine design). Any use other than the use explicitly permitted is prohibited and can result in hazards.

Product Related Information

Read and understand these instructions before performing any procedure with this drive.

 **DANGER**

HAZARD OF ELECTRIC SHOCK, EXPLOSION OR ARC FLASH

- Only appropriately trained persons who are familiar with and understand the contents of this manual and all other pertinent product documentation and who have received safety training to recognize and avoid hazards involved are authorized to work on and with this drive system. Installation, adjustment, repair and maintenance must be performed by qualified personnel.
- The system integrator is responsible for compliance with all local and national electrical code requirements as well as all other applicable regulations with respect to grounding of all equipment.
- Many components of the product, including the printed circuit boards, operate with mains voltage.
- Only use properly rated, electrically insulated tools and measuring equipment.
- Do not touch unshielded components or terminals with voltage present.
- Motors can generate voltage when the shaft is rotated. Prior to performing any type of work on the drive system, block the motor shaft to prevent rotation.
- AC voltage can couple voltage to unused conductors in the motor cable. Insulate both ends of unused conductors of the motor cable.
- Do not short across the DC bus terminals or the DC bus capacitors or the braking resistor terminals.
- Before performing work on the drive system:
 - Disconnect all power, including external control power that may be present. Take into account that the circuit breaker or main switch does not de-energize all circuits.
 - Place a **Do Not Turn On** label on all power switches related to the drive system.
 - Lock all power switches in the open position.
 - Wait 15 minutes to allow the DC bus capacitors to discharge.
 - Follow the instructions given in the chapter "Verifying the Absence of Voltage" in the installation manual of the product.
- Before applying voltage to the drive system:
 - Verify that the work has been completed and that the entire installation cannot cause hazards.
 - If the mains input terminals and the motor output terminals have been grounded and short-circuited, remove the ground and the short circuits on the mains input terminals and the motor output terminals.
 - Verify proper grounding of all equipment.
 - Verify that all protective equipment such as covers, doors, grids is installed and/or closed.

Failure to follow these instructions will result in death or serious injury.

Damaged products or accessories may cause electric shock or unanticipated equipment operation.

 **DANGER**

ELECTRIC SHOCK OR UNANTICIPATED EQUIPMENT OPERATION

Do not use damaged products or accessories.

Failure to follow these instructions will result in death or serious injury.

Contact your local Schneider Electric sales office if you detect any damage whatsoever.

This equipment has been designed to operate outside of any hazardous location. Only install this equipment in zones known to be free of a hazardous atmosphere.

DANGER

POTENTIAL FOR EXPLOSION

Install and use this equipment in non-hazardous locations only.

Failure to follow these instructions will result in death or serious injury.

Your application consists of a whole range of different interrelated mechanical, electrical, and electronic components, the drive being just one part of the application. The drive by itself is neither intended to nor capable of providing the entire functionality to meet all safety-related requirements that apply to your application. Depending on the application and the corresponding risk assessment to be conducted by you, a whole variety of additional equipment is required such as, but not limited to, external encoders, external brakes, external monitoring devices, guards, etc.

As a designer/manufacturer of machines, you must be familiar with and observe all standards that apply to your machine. You must conduct a risk assessment and determine the appropriate Performance Level (PL) and/or Safety Integrity Level (SIL) and design and build your machine in compliance with all applicable standards. In doing so, you must consider the interrelation of all components of the machine. In addition, you must provide instructions for use that enable the user of your machine to perform any type of work on and with the machine such as operation and maintenance in a safe manner.

The present document assumes that you are fully aware of all normative standards and requirements that apply to your application. Since the drive cannot provide all safety-related functionality for your entire application, you must ensure that the required Performance Level and/or Safety Integrity Level is reached by installing all necessary additional equipment.

WARNING

INSUFFICIENT PERFORMANCE LEVEL/SAFETY INTEGRITY LEVEL AND/OR UNINTENDED EQUIPMENT OPERATION

- Conduct a risk assessment according to EN ISO 12100 and all other standards that apply to your application.
- Use redundant components and/or control paths for all critical control functions identified in your risk assessment.
- If moving loads can result in hazards, for example, slipping or falling loads, operate the drive in closed loop mode.
- Verify that the service life of all individual components used in your application is sufficient for the intended service life of your overall application.
- Perform extensive commissioning tests for all potential error situations to verify the effectiveness of the safety-related functions and monitoring functions implemented, for example, but not limited to, speed monitoring by means of encoders, short circuit monitoring for all connected equipment, correct operation of brakes and guards.
- Perform extensive commissioning tests for all potential error situations to verify that the load can be brought to a safe stop under all conditions.

Failure to follow these instructions can result in death, serious injury, or equipment damage.

Drive systems may perform unexpected movements because of incorrect wiring, incorrect settings, incorrect data or other errors.

WARNING

UNANTICIPATED EQUIPMENT OPERATION

- Carefully install the wiring in accordance with the EMC requirements.
- Do not operate the product with unknown or unsuitable settings or data.
- Perform a comprehensive commissioning test.

Failure to follow these instructions can result in death, serious injury, or equipment damage.

WARNING

LOSS OF CONTROL

- The designer of any control scheme must consider the potential failure modes of control paths and, for critical control functions, provide a means to achieve a safe state during and after a path failure. Examples of critical control functions are emergency stop, overtravel stop, power outage and restart.
- Separate or redundant control paths must be provided for critical control functions.
- System control paths may include communication links. Consideration must be given to the implications of unanticipated transmission delays or failures of the link.
- Observe all accident prevention regulations and local safety guidelines (1).
- Each implementation of the product must be individually and thoroughly tested for proper operation before being placed into service.

Failure to follow these instructions can result in death, serious injury, or equipment damage.

(1) For USA: Additional information, refer to NEMA ICS 1.1 (latest edition), Safety Guidelines for the Application, Installation, and Maintenance of Solid State Control and to NEMA ICS 7.1 (latest edition), Safety Standards for Construction and Guide for Selection, Installation and Operation of Adjustable-Speed Drive Systems.

The temperature of the products described in this manual may exceed 80 °C (176 °F) during operation.

WARNING

HOT SURFACES

- Ensure that any contact with hot surfaces is avoided.
- Do not allow flammable or heat-sensitive parts in the immediate vicinity of hot surfaces.
- Verify that the product has sufficiently cooled down before handling it.
- Verify that the heat dissipation is sufficient by performing a test run under maximum load conditions.

Failure to follow these instructions can result in death, serious injury, or equipment damage.

NOTICE

DESTRUCTION DUE TO INCORRECT MAINS VOLTAGE

Before switching on and configuring the product, verify that it is approved for the mains voltage.

Failure to follow these instructions can result in equipment damage.

About the Book



At a Glance

Document Scope

The purpose of this document is:

- to give you mechanical and electrical information related to the drive,
- to show you how to install and wire this drive.

Validity Note

This documentation is valid for the Altivar 610 drive.

The technical characteristics of the devices described in the present document also appear online. To access the information online:

Step	Action
1	Go to the Schneider Electric home page www.schneider-electric.com .
2	In the Search box type the reference of a product or the name of a product range. <ul style="list-style-type: none">• Do not include blank spaces in the reference or product range.• To get information on grouping similar modules, use asterisks (*).
3	If you entered a reference, go to the Product Datasheets search results and click on the reference that interests you. If you entered the name of a product range, go to the Product Ranges search results and click on the product range that interests you.
4	If more than one reference appears in the Products search results, click on the reference that interests you.
5	Depending on the size of your screen, you may need to scroll down to see the datasheet.
6	To save or print a datasheet as a .pdf file, click Download XXX product datasheet .

The characteristics that are presented in the present document should be the same as those characteristics that appear online. In line with our policy of constant improvement, we may revise content over time to improve clarity and accuracy. If you see a difference between the document and online information, use the online information as your reference.

Related Documents

Use your tablet or your PC to quickly access detailed and comprehensive information on all our products on www.schneider-electric.com.

The internet site provides the information you need for products and solutions:

- The whole catalog for detailed characteristics and selection guides,
- The CAD files to help design your installation, available in over 20 different file formats,
- All software and firmware to maintain your installation up to date,
- A large quantity of White Papers, Environment documents, Application solutions, Specifications... to gain a better understanding of our electrical systems and equipment or automation,
- And finally all the User Guides related to your drive, listed below:

(Other option manuals and Instruction sheets are available on www.schneider-electric.com)

Title of Documentation	Catalog Number
Altivar Easy 610 Catalog	DIA2ED2140702EN (English)
ATV610 Getting Started	EAV64374 (English), EAV64379 (Chinese)
ATV610 Installation Manual	EAV64381 (English), EAV64386 (Chinese)
ATV610 Programming Manual	EAV64387 (English) EAV64393 (Chinese)
ATV610 Communication Parameters File	EAV64394 (English)
ATV610 Modbus Manual	EAV64395 (English)
ATV610 PROFIBUS DP manual	EAV64396 (English)

You can download these technical publications and other technical information from our website at www.schneider-electric.com/en/download

Terminology

The technical terms, terminology, and the corresponding descriptions in this manual normally use the terms or definitions in the relevant standards.

In the area of drive systems this includes, but is not limited to, terms such as **error, error message, failure, fault, fault reset, protection, safe state, safety function, warning, warning message**, and so on.

Among others, these standards include:

- IEC 61800 series: Adjustable speed electrical power drive systems
- IEC 61508 Ed.2 series: Functional safety of electrical/electronic/programmable electronic safety-related
- EN 954-1 Safety of machinery - Safety related parts of control systems
- ISO 13849-1 & 2 Safety of machinery - Safety related parts of control systems
- IEC 61158 series: Industrial communication networks - Fieldbus specifications
- IEC 61784 series: Industrial communication networks - Profiles
- IEC 60204-1: Safety of machinery - Electrical equipment of machines – Part 1: General requirements

In addition, the term **zone of operation** is used in conjunction with the description of specific hazards, and is defined as it is for a **hazard zone** or **danger zone** in the EC Machinery Directive (2006/42/EC) and in ISO 12100-1.

Also see the glossary at the end of this manual.

Contact Us

Select your country on:

www.schneider-electric.com/contact

Schneider Electric Industries SAS

Head Office

35, rue Joseph Monier

92500 Rueil-Malmaison

France

Chapter 1

Introduction

What Is in This Chapter?

This chapter contains the following topics:

Topic	Page
Verifying the Absence of Voltage	12
Drive Overview	13
Accessories and Options	16
Green Premium™	16
Steps for setting up the drive	17
Preliminary Instructions	18

Verifying the Absence of Voltage

Instructions

The DC bus voltage level is determined by measuring the voltage between the DC bus terminals PA/+ and PC/-.

The location of the DC bus terminals depends on the drive model.

Identify your drive model by referring to the nameplate of the drive. Then, refer to the chapter "Wiring the Power Part" (*see page 67*) for the location of the DC bus terminals PA/+ and PC/-.

DANGER

HAZARD OF ELECTRIC SHOCK, EXPLOSION OR ARC FLASH

- Only appropriately trained persons who are familiar with and understand the contents of this manual and all other pertinent product documentation and who have received safety training to recognize and avoid hazards involved are authorized to work on and with this drive system. Installation, adjustment, repair and maintenance must be performed by qualified personnel.
- The system integrator is responsible for compliance with all local and national electrical code requirements as well as all other applicable regulations with respect to grounding of all equipment.
- Many components of the product, including the printed circuit boards, operate with mains voltage.
- Only use properly rated, electrically insulated tools and measuring equipment.
- Do not touch unshielded components or terminals with voltage present.
- Motors can generate voltage when the shaft is rotated. Prior to performing any type of work on the drive system, block the motor shaft to prevent rotation.
- AC voltage can couple voltage to unused conductors in the motor cable. Insulate both ends of unused conductors of the motor cable.
- Do not short across the DC bus terminals or the DC bus capacitors or the braking resistor terminals.
- Before performing work on the drive system:
 - Disconnect all power, including external control power that may be present. Take into account that the circuit breaker or main switch does not de-energize all circuits.
 - Place a **Do Not Turn On** label on all power switches related to the drive system.
 - Lock all power switches in the open position.
 - Wait 15 minutes to allow the DC bus capacitors to discharge.
 - Follow the instructions given in the chapter "Verifying the Absence of Voltage" in the installation manual of the product.
- Before applying voltage to the drive system:
 - Verify that the work has been completed and that the entire installation cannot cause hazards.
 - If the mains input terminals and the motor output terminals have been grounded and short-circuited, remove the ground and the short circuits on the mains input terminals and the motor output terminals.
 - Verify proper grounding of all equipment.
 - Verify that all protective equipment such as covers, doors, grids is installed and/or closed.

Failure to follow these instructions will result in death or serious injury.

Procedure



Perform the following actions to verify the absence of voltage

Step	Action
1	Measure the voltage on the DC bus between the DC bus terminals (PA/+ and PC/-) using a properly rated voltmeter to verify that the voltage is less than 42 Vdc
2	If the DC bus capacitors do not discharge properly, contact your local Schneider Electric representative. Do not repair or operate the product.
3	Verify that no other voltage is present in the drive system.

Drive Overview

Frame Sizes

The family of Altivar 610 includes 6 frame sizes of IP20 products.

Frame Size 1	Frame Size 2
3-phase 380...415 V, 0.75...7.5 kW, 1...10 HP	3-phase 380...415 V, 11 and 15 kW, 15 and 20 HP
	
ATV610U07N4...U75N4	ATV610D11N4 and D15N4

Frame Size 3	Frame Size 4
3-phase 380...415 V, 18.5 and 22 kW, 25 and 30 HP	3-phase 380...415 V, 30...45 kW, 40...60 HP
	
ATV610D18N4 and D22N4	ATV610D30N4...D45N4

Frame Size 5	Frame Size 6
3-phase 380...415 V, 55...90 kW, 75... 125 HP	3-phase 380...415 V, 110...160 kW 150...250 HP
 <p>The image shows a Schneider Electric Altivar Frame Size 5 Variable Frequency Drive (VFD). It is a tall, grey, vertical unit with a control panel on the right side featuring a green digital display and several buttons. The front panel has a green 'Altivar' logo near the top and the 'Schneider Electric' logo at the bottom. There are also safety warning labels and a QR code on the front panel.</p>	 <p>The image shows a Schneider Electric Altivar Frame Size 6 Variable Frequency Drive (VFD). It is a taller, grey, vertical unit compared to the Frame Size 5 model. It features a similar control panel with a green digital display and buttons. The front panel includes a green 'Altivar' logo, the 'Schneider Electric' logo, and safety warning labels with a QR code.</p>
ATV610D55N4...D90N4	ATV610C11N4...C16N4,

Catalog Number Description

	ATV	610	D	75	N4
Product Range ATV Altivar					
Product Type 610 610: Standard product					
Factor for power rating U power x 0.1 D power x 1 C power x 10					
Power rating 07 - 11 - 13 - 15 - 55 - 75					
Power part supply N4 380 Vac (380...415 Vac) 3 phase N4Z 380 Vac (380...415 Vac) 3 phase, product without Plain Text Display Terminal					

Nameplate example

The nameplate contains the following data:

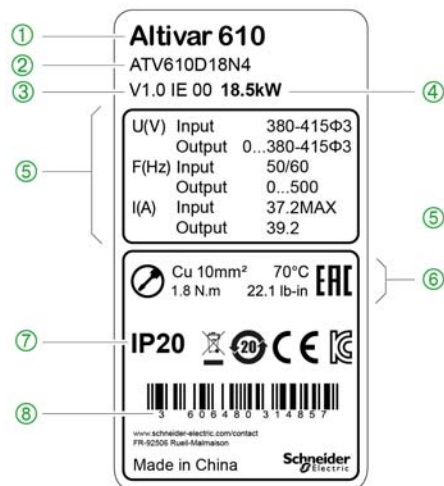

- ① Product type ② Catalog number ③ Firmware version
- ④ Power rating ⑤ Power part information
- ⑥ Power part cable information ⑦ Degree of protection ⑧ Serial number

Accessories and Options

Introduction

Altivar Easy 610 drives are designed to take numerous accessories and options to increase their functionality. For a detailed description and catalog numbers, refer to the Catalog (*see page 9*).

All accessories and options come with an instruction sheet to help installation and commissioning. Therefore you will only find here a short product description.

Accessories

IP upgrade

- Metal conduit box for size 6 product for IP21 degree of protection on bottom side.

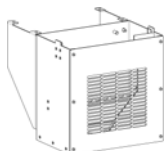

Plain text display terminal

- Remote mounting kit for mounting on enclosure door

Filters

dv/dt filters

Options

I/O extension modules

- Digital and analog I/O module
- Relay output module

Communication

- PROFIBUS DP V1 communication module

Green Premium™

Description

Information on the environmental impact of products, their resource efficiency, and end-of-life instructions.

Easy access to information: "Check Your Product"

Certificates and relevant product information available at the address:

www.schneider-electric.com/green-premium

You can download RoHS and REACH compliance declarations, Product Environmental Profiles (PEP) and End-of-Life instructions (EoLi).



Steps for setting up the drive

Procedure

INSTALLATION

① Receive and inspect the drive controller

- ❑ Check that the catalog number printed on the label is the same as that on the purchase order
- ❑ Remove the drive from its packaging and check that it has not been damaged

② Verify the supply mains

- ❑ Verify that the supply mains is compatible with the power part supply range of the drive.

③ Mount the drive

- ❑ Mount the drive in accordance with the instructions in this document
- ❑ Install the transformer(s), if any
- ❑ Install any internal and external options

④ Wire the drive

- ❑ Connect the motor, ensuring that its connections correspond to the voltage
- ❑ Connect the supply mains, after making sure that the power is off
- ❑ Connect the control

Steps 1 to 4 must be performed with the power off.



⑤ PROGRAMMING

Refer to the Programming Manual

Preliminary Instructions

Inspecting the product

Damaged products or accessories may cause electric shock or unanticipated equipment operation.

DANGER

ELECTRIC SHOCK OR UNANTICIPATED EQUIPMENT OPERATION

Do not use damaged products or accessories.

Failure to follow these instructions will result in death or serious injury.

Contact your local Schneider Electric sales office if you detect any damage whatsoever.

Step	Action
1	Verify that the catalog number printed on the nameplate (<i>see page 15</i>) corresponds to the purchase order.
2	Before performing any installation work, inspect the product for visible damage.

Handling

WARNING

INCORRECT HANDLING

- Follow all handling instructions provided in this manual and in all associated product documentation.
- Handle and store the product in its original packaging.
- Do not handle and store the product if the packaging is damaged or appears to be damaged.
- Take all measures required to avoid damage to the product and other hazards when handling or opening the packaging.

Failure to follow these instructions can result in death, serious injury, or equipment damage.

To help protect the drive before installation, handle and store the device in its packaging. Ensure that the ambient conditions are acceptable.

Altivar Easy drives of frame sizes 1 up to 3 can be removed from their packaging and installed without a handling device.

Higher frame size drives require a handling device. These drives are equipped with lifting lugs.

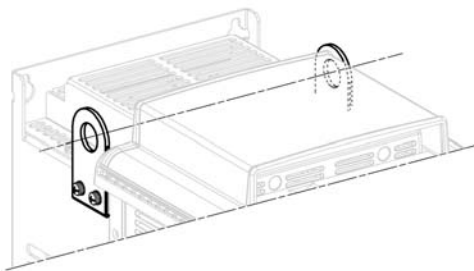

Chapter 2

Technical Data

What Is in This Chapter?

This chapter contains the following sections:

Section	Topic	Page
2.1	Environment Data	20
2.2	Mechanical Data	22
2.3	Electrical Data - Drive Ratings	28
2.4	Electrical Data - Upstream Protective Device	31

Section 2.1 Environment Data

What Is in This Section?

This section contains the following topics:

Topic	Page
Temperature Conditions	21
Altitude Conditions	21
Chemical and Mechanical Conditions	21

Temperature Conditions

Climatic Environmental Conditions for Transportation and Storage

The environment during transportation and storage must be dry and free from dust.

Storage	Temperature	°C	-40...70
		°F	-40...158
Transportation	Temperature	°C	-40...70
		°F	-40...158
Relative humidity		%	5...95

Climatic Environmental Conditions for Operation

The maximum permissible ambient temperature during operation depends on the mounting distances between the devices and on the required power. Observe the pertinent instructions in the chapter Drive Mounting (*see page 39*).

Frame sizes 1...6 ATV610... products	Temperature without derating	°C	-15...45
		°F	5...113
	Temperature with derating of output power (1)	°C	Up to 60
		°F	Up to 140
	Temperature with derating of output power (1) and control without Graphic display terminal	°C	Up to 70
		°F	-40...158
All products	Relative humidity without condensing	%	5...95

(1) Refer to Derating Curves section (*see page 44*).

Altitude Conditions

Operating Altitude

All frame sizes

Altitude	Supply voltage	Supply Electrical Network			Derating
		TT/TN	IT	Corner-Grounded	
Up to 1000 m (3300 ft)	380...415 V	✓	✓	✓	o
1000...2000 m (3300...6600 ft)	380...415 V	✓	✓	✓	✓
2000...3800 m (6600...12400 ft)	380...415 V	✓	✓	–	✓
3800...4800 m (12400...15700 ft)	380...415 V	✓	–	–	✓
Legend: ✓: Derate the nominal current of the drive by 1% for each additional 100 m. o: Without derating –: Not applicable					

Chemical and Mechanical Conditions

Withstand to harsh environments, conforming to IEC/EN 60721-3-3

- Chemical active substances, class 3C3
- Mechanical active substances, class 3S3
- Mechanical conditions, class 3M3

Section 2.2 Mechanical Data

Dimensions and Weights

About the drawings

All drawings CAD files can be downloaded from www.schneider-electric.com

Frame Size 1

IP20 Drives - Rear and Side View With Top Cover - Side View Without Top Cover

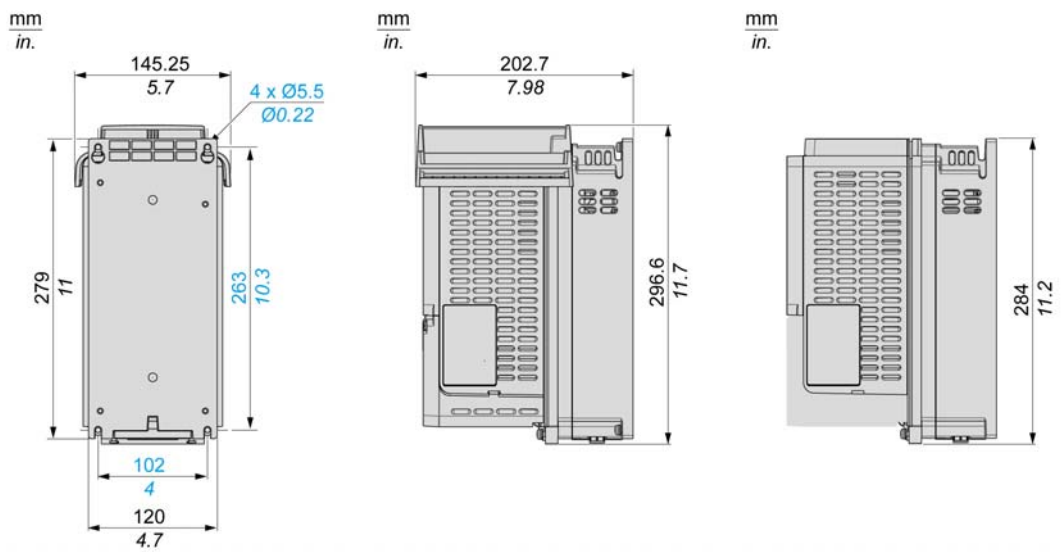

Weights

Catalog Number	Weight in kg (lb)
ATV610U07N4...U30N4	2.4 (5.3)
ATV610U40N4	4.0 (8.8)
ATV610U55N4, ATV610U75N4	4.1 (9)

Frame size 2

IP20 Drives - Rear and Side View With Top Cover - Side View Without Top Cover

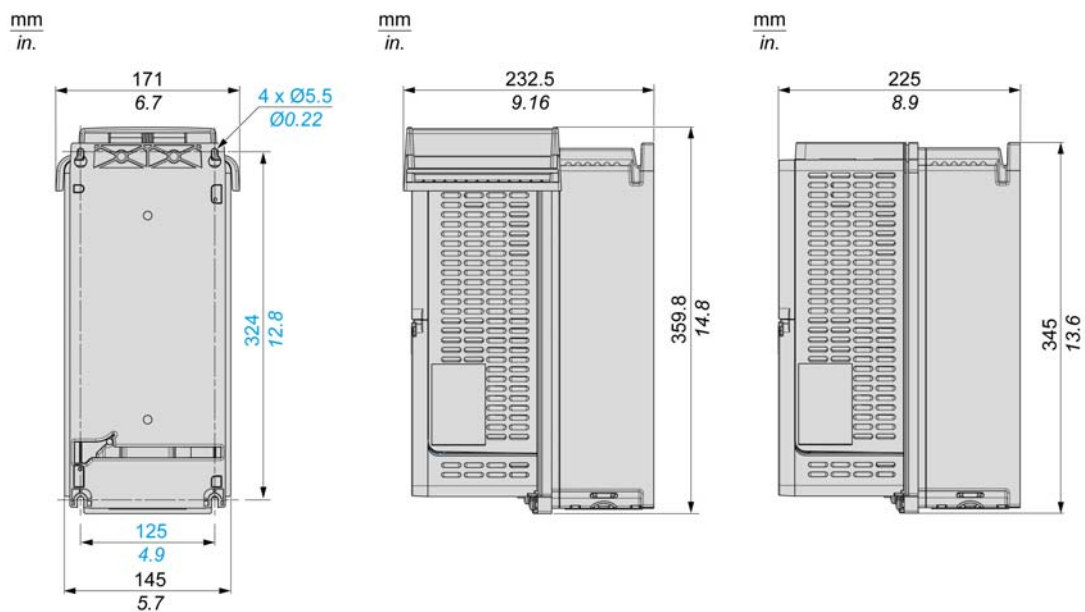

Weights

Catalog Number	Weight in kg (lb)
ATV610D11N4 and ATV610D15N4	7.2 (15.9)

Frame size 3

IP20 Drives - Rear and Side View With Top Cover - Side View Without Top Cover

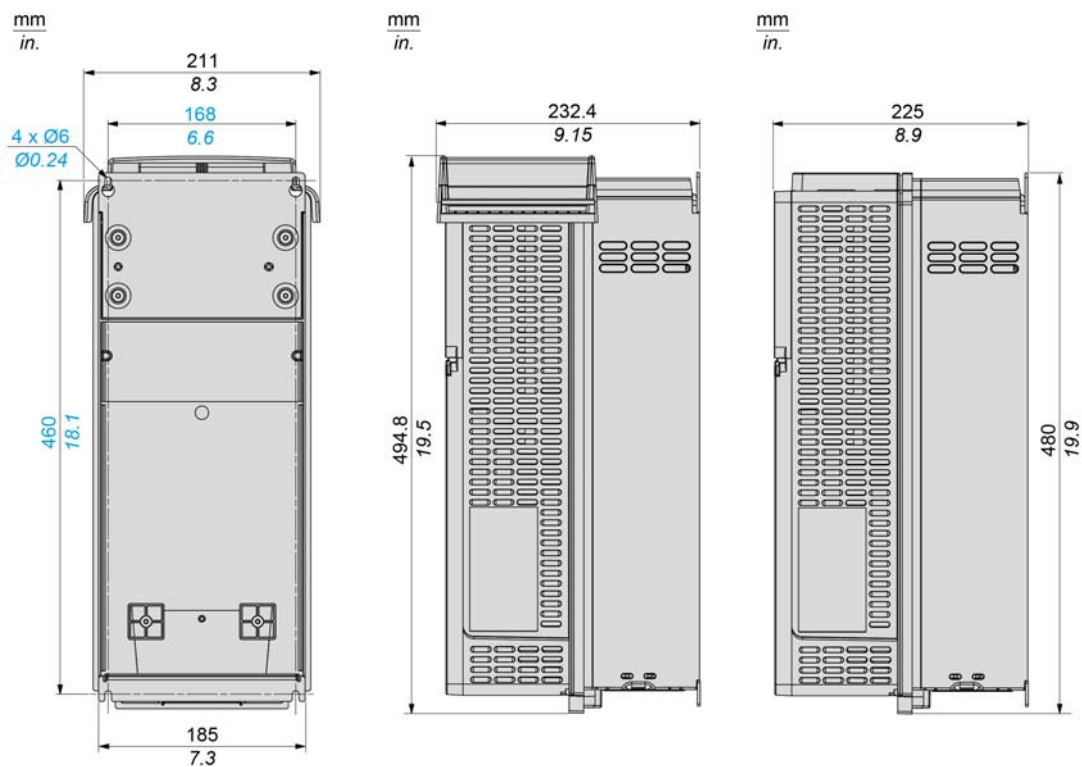

Weights

Catalog Number	Weight in kg (lb)
ATV610D18N4 and ATV610D22N4	14 (30.9)

Frame size 4

IP20 Drives - Rear and Side View With Top Cover - Side View Without Top Cover

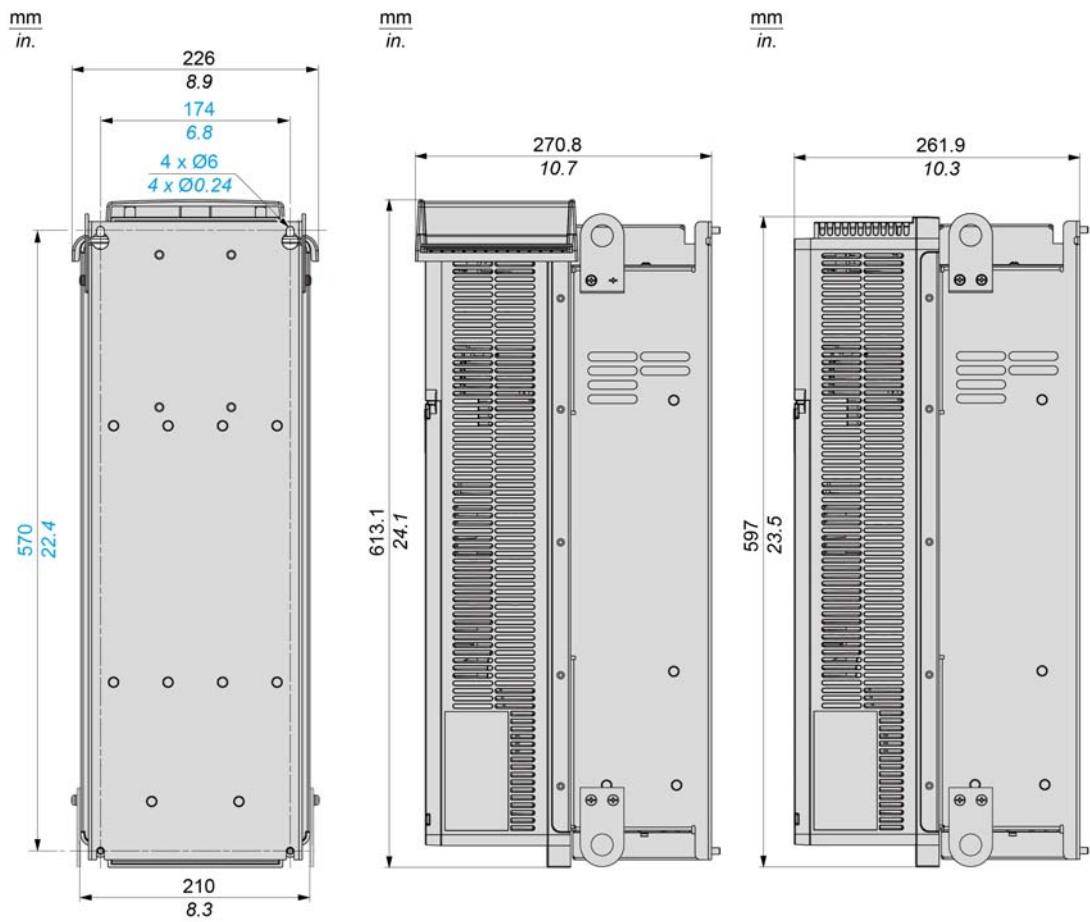

Weights

Catalog Number	Weight in kg (lb)
ATV610D30N4...ATV610D45N4	28 (61.7)

Frame size 5

IP20 Drives - Rear and Side View With Top Cover - Side View Without Top Cover

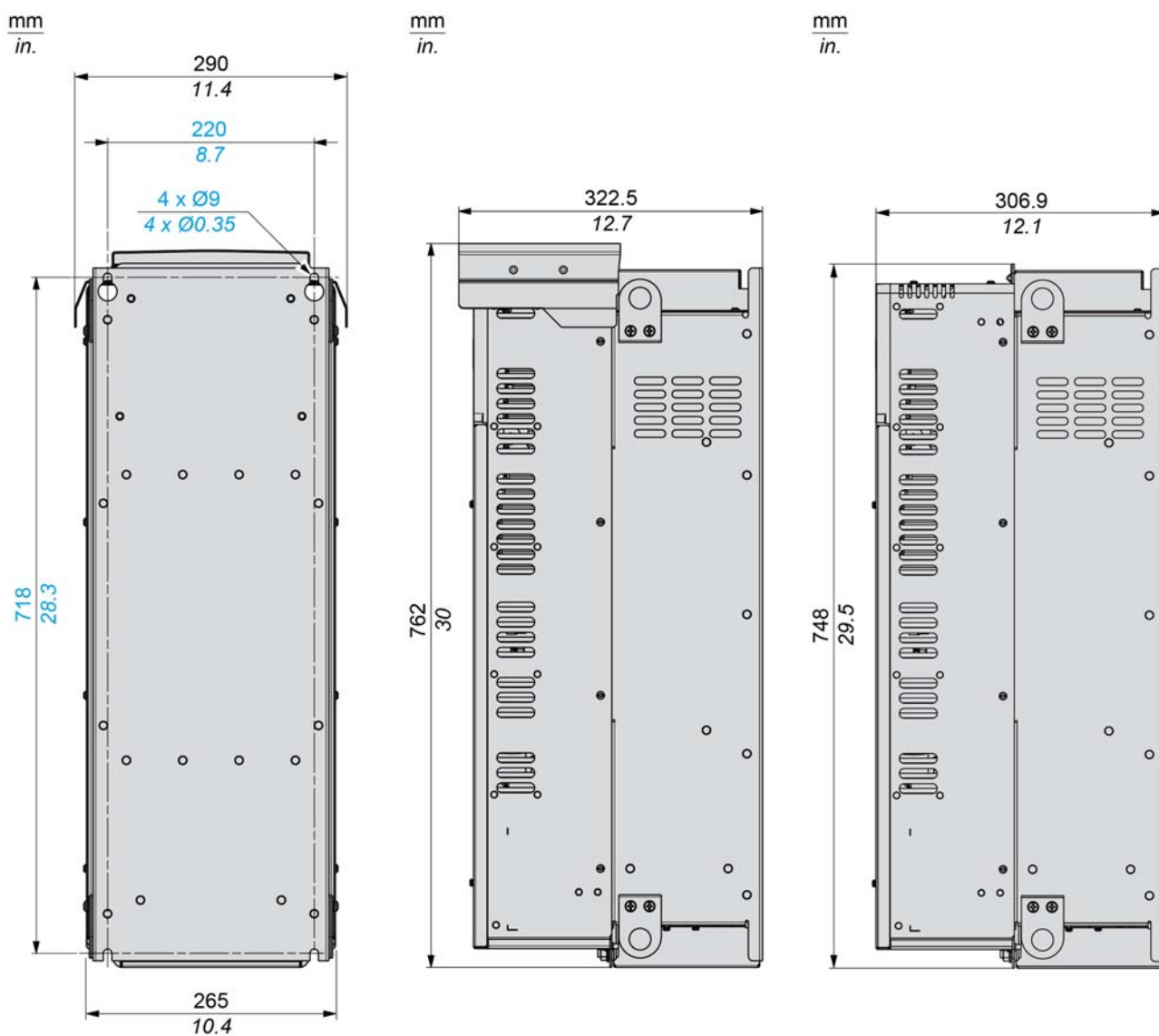

Weights

Catalog Number	Weight in kg (lb)
ATV610D55N4...ATV610D90N4	53.7 (118.4)

Frame size 6

IP20 on Top and IP00 on bottom Drives - Rear and Side View With Top Cover

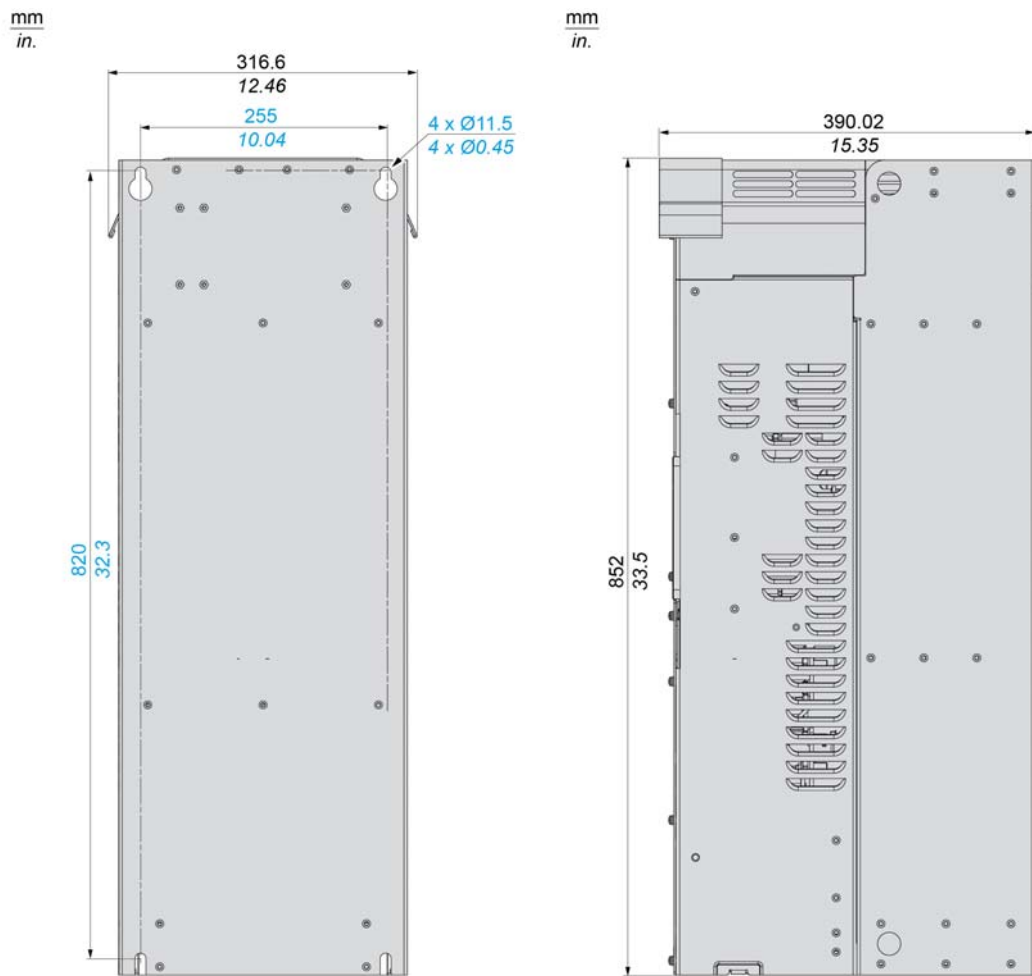

IP20 Drives - Rear, Front and Side View With Top Cover and Conduit Box

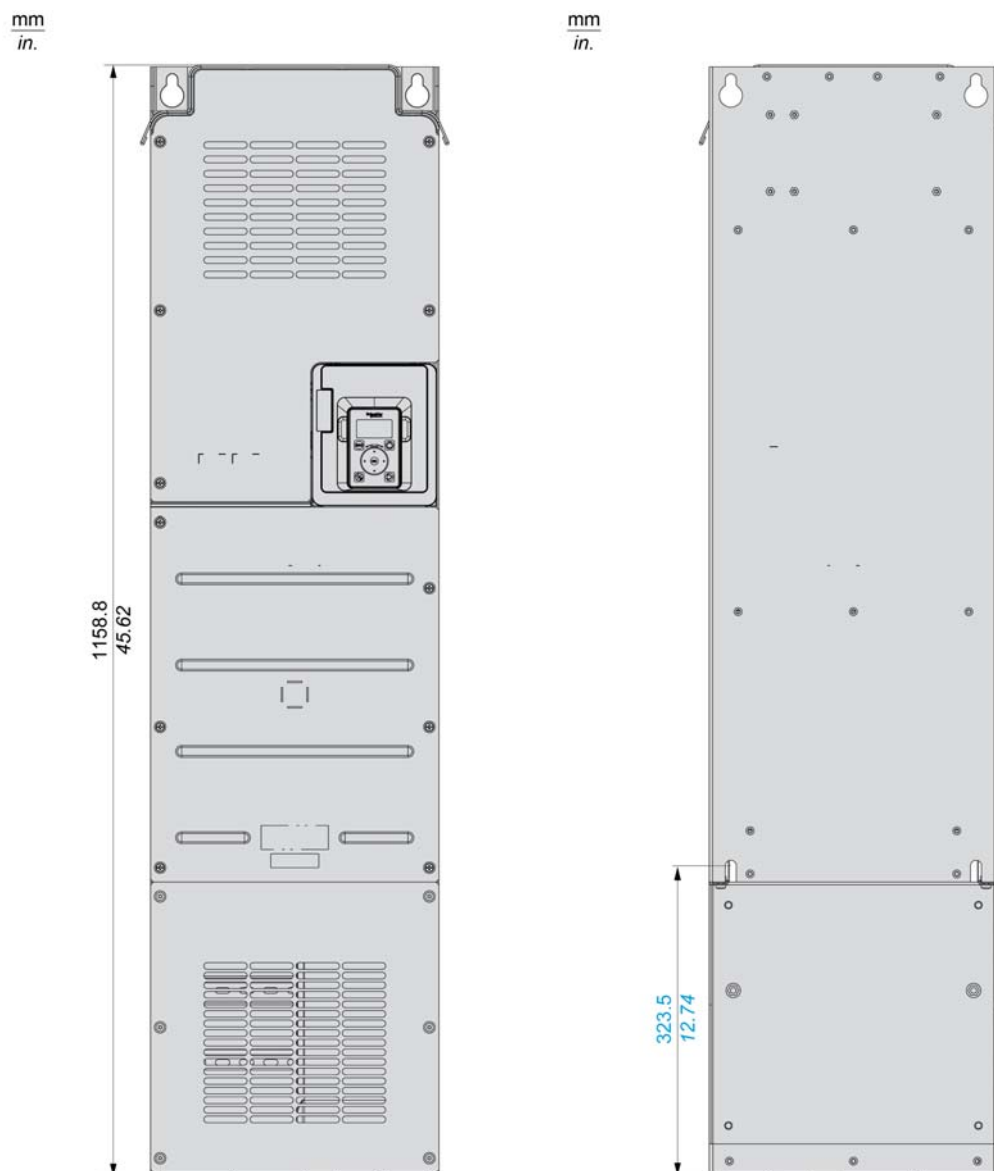

Weights

Catalog Number	Weight in kg (lb)
ATV610C11N4...ATV610C16N4	82 (181)

Section 2.3

Electrical Data - Drive Ratings

What Is in This Section?

This section contains the following topics:

Topic	Page
Drive Ratings in Normal Duty	29
Drive Ratings in Heavy Duty	30

Drive Ratings in Normal Duty

Normal Duty

Normal duty values are given for applications requiring a slight overload (up to 120%).

NOTE:

- Refer to the catalog for the fuse coordination table.
- For motor overload and drive thermal monitoring functions, refer to the ATV610 Programming manual (*see page 9*).

IP20 Products (frame sizes 1...5) and IP20 on Top, IP00 on bottom products (frame size 6), 3-Phase Power Part Supply Voltage 380...415 V 50/60 Hz

Catalog Number and Size [•]		Nominal Power (1)		Power Part Supply				Drive (output)	
				Max. Input Current		Apparent Power	Max. Inrush Current (2)	Nominal Current (1)	Max. Transient current (1) (3)
				at 380 Vac	at 415 Vac				
		kW	HP	A	A	kVA	A	A	A
ATV610U07N4	[1]	0.75	1	3.1	2.9	2.1	8	2.2	2.4
ATV610U15N4	[1]	1.5	2	5.7	5.3	3.8	8	4	4.4
ATV610U22N4	[1]	2.2	3	7.8	7.1	5.1	8	5.6	6.2
ATV610U30N4	[1]	3	-	10.1	9.2	6.6	34	7.2	7.9
ATV610U40N4	[1]	4	5	8.8	8.5	6.1	33	9.3	10.2
ATV610U55N4	[1]	5.5	7 1/2	11.6	11.0	7.9	34	12.7	14.0
ATV610U75N4	[1]	7.5	10	14.7	13.7	9.9	34	15.8	17.4
ATV610D11N4	[2]	11	15	22.0	20.7	14.9	40	23.5	25.9
ATV610D15N4	[2]	15	20	29.4	27.7	19.9	40	31.7	34.9
ATV610D18N4	[3]	18.5	25	37.2	35.2	25.3	76	39.2	43.1
ATV610D22N4	[3]	22	30	41.9	39.0	28.0	76	46.3	50.9
ATV610D30N4	[4]	30	40	62.5	59.7	42.9	91	61.5	67.7
ATV610D37N4	[4]	37	50	76.6	72.9	52.4	101	74.5	82.0
ATV610D45N4	[4]	45	60	92.9	88.3	63.5	124	88	96.8
ATV610D55N4	[5]	55	75	111.5	105.6	75.9	167	120	132.0
ATV610D75N4	[5]	75	100	147.9	139.0	99.9	186	145	159.5
ATV610D90N4	[5]	90	125	177.8	168.5	121.1	240	173	190.3
ATV610C11N4	[6]	110	150	201	165.0	118.6	325	211	232
ATV610C13N4	[6]	132	200	237	213.0	153.1	325	250	275
ATV610C16N4	[6]	160	250	284	261.0	187.6	325	302	332

(1) The switching frequency is adjustable:

- From 2...12 kHz for drive frame sizes 1 to 4, rated value: 4 kHz
- From 1...8 kHz for drive frame sizes 5 and 6, rated value: 2.5 kHz

For operation at switching frequencies higher than the rated value. Derating must be applied to the drive (output) current (*see page 44*). In this case, switching frequency can be reduced if an excessive temperature rise occurs.

(2) Peak current when power is switched On, for the maximum supply mains voltage.

(3) The drive is designed to run up to 60 s at 110% of nominal current.

Drive Ratings in Heavy Duty

Heavy Duty

Heavy-duty values are given for applications requiring a significant overload (up to 150%).

NOTE:

- Refer to the catalog for the fuse coordination table.
- For motor overload and drive thermal monitoring functions, refer to the ATV610 Programming manual (see page 9).

IP20 Products (frame sizes 1...5) and IP20 on Top, IP00 on bottom products, 3-Phase Power Part Supply Voltage 380...415 V 50/60 Hz

Catalog Number and Size [•]		Nominal Power (1)		Power Part Supply				Drive (output)	
				Max. Input Current		Apparent Power	Max. Inrush Current(2)	Nominal Current (1)	Max. Transient current (1) (3)
				at 380 Vac	at 415 Vac				
		kW	HP	A	A				
ATV610U07N4	[1]	0.37	1/2	1.7	1.5	1.1	8	1.5	2.3
ATV610U15N4	[1]	0.75	1	3.1	2.8	2.0	8	2.2	3.3
ATV610U22N4	[1]	1.5	2	5.6	5.1	3.7	8	4	6.0
ATV610U30N4	[1]	2.2	3	7.6	7	5.0	34	5.6	8.4
ATV610U40N4	[1]	3	-	7.2	6.7	4.8	33	7.2	10.8
ATV610U55N4	[1]	4	5	8.9	8.6	6.2	34	9.3	14.0
ATV610U75N4	[1]	5.5	7 1/2	11.3	10.7	7.7	34	12.7	19.1
ATV610D11N4	[2]	7.5	10	16.4	15.7	11.3	40	16.5	24.8
ATV610D15N4	[2]	11	15	23	21.9	15.7	40	23.5	35.3
ATV610D18N4	[3]	15	20	31.6	30.3	21.8	76	31.7	47.6
ATV610D22N4	[3]	18.5	25	36	33.8	24.3	76	39.2	58.8
ATV610D30N4	[4]	22	30	49.7	46.3	33.3	91	46.3	69.5
ATV610D37N4	[4]	30	40	65.8	61.8	44.4	101	59.6	89.4
ATV610D45N4	[4]	37	50	80.5	75.8	54.5	124	74.5	112
ATV610D55N4	[5]	45	60	95.9	91.2	65.6	167	88	132.0
ATV610D75N4	[5]	55	75	115.8	110.0	79.1	186	106	159.0
ATV610D90N4	[5]	75	100	155.8	149.1	107.2	240	145	217.5
ATV610C11N4	[6]	90	125	170	160	115.0	325	173	259.5
ATV610C13N4	[6]	110	150	201	188	135.1	325	211	317
ATV610C16N4	[6]	132	200	237	224	161.0	325	250	375

(1) The switching frequency is adjustable:

- From 2...12 kHz for drive frame sizes 1 to 4, rated value: 4 kHz
- From 1...8 kHz for drive frame sizes 5 and 6, rated value: 2.5 kHz

For operation at switching frequencies higher than the rated value. Derating must be applied to the drive (output) current (see page 44). In this case, switching frequency can be reduced if an excessive temperature rise occurs.

(2) Peak current when power is switched On, for the maximum supply mains voltage.

(3) The drive is designed to run up to 60 s at 110% of nominal current.

Section 2.4

Electrical Data - Upstream Protective Device

What Is in This Section?

This section contains the following topics:

Topic	Page
Introduction	32
Prospective Short-Circuit Current	34
IEC Type Circuit-Breaker as SCPD	37
IEC Fuses	38

Introduction

Overview

 **DANGER**

INSUFFICIENT PROTECTION AGAINST OVERCURRENTS CAN CAUSE FIRE OR EXPLOSION

- Use properly rated overcurrent protection devices.
- Use the fuses/circuit breakers specified.
- Do not connect the product to a supply mains whose prospective short circuit current rating (current that flows during a short circuit) exceeds the specified maximum permissible value.
- When rating the upstream mains fuses and the cross sections as well as the lengths of the mains cables, take into account the minimum required prospective short-circuit current (Isc). Refer to the Upstream Protection Device section.
- If the minimum required prospective short-circuit current (Isc) is not available, apply the instructions given in the section below.

Failure to follow these instructions will result in death or serious injury.

The specified maximum permissible values and products for IEC compliance are specified in the catalog.

General

- The Short Circuit Protective Device (SCPD) rated to the drive will help protect the upstream installation in case of a short-circuit internal to the drive and mitigate the damage to the drive and its surrounding area.
- The SCPD rated to the drive is mandatory to help ensuring the safety of the Power Drive System. It comes in addition to the upstream branch circuit protection which is in compliance with the local regulation for electrical installation.
- The SCPD shall mitigate the damage in case of detected error condition such as an internal short-circuit of the drive.
- The SCPD must take into account both following characteristics...
 - a maximum prospective short-circuit current
 - a minimum required prospective short-circuit current (Isc).

If the minimum required prospective short-circuit current (Isc) is not available, increase the power of the transformer or decrease the length of the cables

In other cases, contact your Schneider Electric Customer Care Center (CCC) www.se.com/CCC for specific selection of Short Circuit Protective Device (SCPD).

Wiring Diagram

This diagram shows an example of installation with both SCPD types, Circuit-breaker (*see page 37*) and Fuse link rated to the drive.

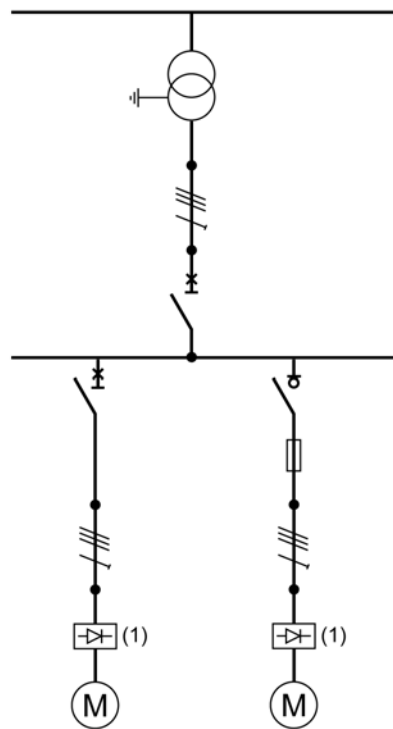

(1) Drive

Prospective Short-Circuit Current

Calculation

The prospective short-circuit current shall be computed at the drive connection points.



We recommend using the Schneider Electric tool Ecodial Advance Calculation [available on www.se.com/en/product-range-presentation/61013-ecodial-advance-calculation/](http://www.se.com/en/product-range-presentation/61013-ecodial-advance-calculation/)

The following equations allow to estimate the value of the symmetrical three-phase prospective short-circuit current (I_{sc}) at the drive connection points.

$$X_t = \frac{U^2}{S_n} \cdot usc$$

$$Z_{cc} = \sqrt{\left(\rho \cdot \frac{l}{S} + R_f\right)^2 + (X_t + X_c \cdot l + X_f)^2}$$

$$I_{sc} = \frac{U}{\sqrt{3}} \cdot \frac{1}{Z_{cc}}$$

- I_{sc}** Symmetrical three-phase prospective short-circuit current (kA)
- X_t** Transformer reactance
- U** No-load phase to phase voltage of the transformer (V)
- S_n** Apparent transformer power (kVA)
- usc** Short-circuit voltage, according to the transformer data sheet (%)
- Z_{cc}** Total short-circuit impedance (m Ω)
- ρ** Conductor resistivity e.g. Cu: 0.01851 m Ω .mm
- l** Conductor length (mm)
- S** Conductor cross section (mm²)
- X_c** Conductor lineic reactance (0.0001 m Ω /mm)
- R_f, X_f** Resistance and reactance of the line filter (m Ω) (*see page 36*)

Example of Calculation with Copper Cable (without line filter)

Transformer 50 Hz	U 400 Vac Usc	Cable Cross Section	Isc depending on cable length in m(ft)							
			10 (33)	20 (66)	40 (131)	80 (262)	100 (328)	160 (525)	200 (656)	320 (1050)
kVA	%	mm ² (AWG)	kA	kA	kA	kA	kA	kA	kA	kA
100	4	2.5 (14)	2.3	1.4	0.8	0.4	0.3	0.2	0.2	0.1
		4 (12)	2.9	2.0	1.2	0.6	0.5	0.3	0.2	0.2
		6 (10)	3.2	2.6	1.6	0.9	0.7	0.5	0.4	0.2
		10 (8)	3.4	3.1	2.3	1.4	1.2	0.8	0.6	0.4
		25 (4)	3.5	3.4	3.1	2.5	2.2	1.6	1.4	0.9
		50 (0)	3.5	3.5	3.3	3.0	2.8	2.3	2.1	1.5
		70 (00)	3.5	3.5	3.4	3.1	2.9	2.6	2.3	1.8
		120 (250 MCM)	3.6	3.5	3.4	3.2	3.1	2.8	2.6	2.1
250	4	6 (10)	5.7	3.4	1.8	0.9	0.7	0.5	0.4	0.2
		10 (8)	7.1	5.0	2.9	1.5	1.2	0.8	0.6	0.4
		25 (4)	8.4	7.4	5.5	3.4	2.8	1.8	1.5	0.9
		50 (0)	8.6	8.1	7.0	5.2	4.5	3.2	2.7	1.8
		70 (00)	8.6	8.2	7.3	5.8	5.2	3.9	3.3	2.3
		120 (250 MCM)	8.7	8.3	7.6	6.5	6.0	4.8	4.2	3.0
400	4	6 (10)	6.6	3.6	1.8	0.9	0.7	0.5	0.4	0.2
		10 (8)	9.2	5.6	3.0	1.5	1.2	0.8	0.6	0.4
		25 (4)	12	9.9	6.5	3.6	2.9	1.9	1.5	1.0
		50 (0)	13	12	9.3	6.1	5.1	3.4	2.8	1.8
		70 (00)	13	12	10	7.2	6.2	4.4	3.6	2.4
		120 (250 MCM)	13	13	11	8.6	7.6	5.7	4.9	3.4
800	6	6 (10)	6.9	3.7	1.9	0.9	0.7	0.5	0.4	0.2
		10 (8)	10	5.8	3.0	1.5	1.2	0.8	0.6	0.4
		25 (4)	15	11	6.9	3.7	3.0	1.9	1.5	1.0
		50 (0)	17	15	11	6.5	5.4	3.5	2.9	1.8
		70 (00)	17	15	12	7.9	6.7	4.6	3.7	2.4
		120 (250 MCM)	17	16	13	9.8	8.6	6.2	5.2	3.5
1000	6	6 (10)	7.1	3.7	1.9	0.9	0.7	0.5	0.4	0.2
		10 (8)	11	6.0	3.1	1.5	1.2	0.8	0.6	0.4
		25 (4)	18	12	7.1	3.7	3.0	1.9	1.5	1.0
		50 (0)	21	17	12	6.7	5.5	3.6	2.9	1.8
		70 (00)	21	18	13	8.4	7.0	4.7	3.8	2.4
		120 (250 MCM)	22	19	16	11	9.3	6.5	5.4	3.6

Additional Line Filter Option

If a line input filter option is required for the installation such as a line reactor or a passive harmonic filter, the minimum prospective short-circuit current capability of the source is reduced at the drive connection point and shall be estimated (*see page 34*) with the impedance values given in the table below.

Then, the SCPD type shall be selected according to the drive. If no selection is available, Schneider Electric Customer Care Center (CCC) www.se.com/CCC should be contacted.

EMC filter series have no significant effect on the minimum prospective short-circuit current capability of the main source.

Through the line option, the I_{sc} will be limited to a maximum value independent of the transformer and cable. **Therefore the below equations can be used to estimate the minimum prospective short-circuit current capability.**

$$10 \text{ m}\Omega \leq X_f \leq 400 \text{ m}\Omega \Rightarrow I_{sc_{\max}} (\text{kA}) = 4.7 - 0.7 \cdot \text{Log}(X_f)$$

$$400 \text{ m}\Omega \leq X_f \leq 2000 \text{ m}\Omega \Rightarrow I_{sc_{\max}} (\text{kA}) = 2.05 - 0.26 \cdot \text{Log}(X_f)$$

Log: Natural logarithm

Line Choke Filters Impedance Values

Line Choke Filter	Xf in mΩ
VZ1L004M010 , VW3A4551	700
VZ1L007UM50 , VW3A4552	300
VZ1L018UM20 , VW3A4553	100
VW3A4554	70
VW3A4555	30
VW3A4556	20

IEC Type Circuit-Breaker as SCPD

Function

The circuit-breaker offers enhanced features versus fuse-link since it cumulates 3 functionalities:

- insulation with lock,
- switch (full load interruption),
- downstream short-circuit protection without replacement.

Selection Table

Schneider Electric circuit-breaker, setting and limits shall be selected according to the following table:

Catalog Number	Circuit-Breaker	I _{r m}	Minimum I _{sc}
	to IEC 60947-2	(A)	(A)
ATV610U07N4	GV2L08	51	100
ATV610U15N4	GV2L10	78	200
ATV610U22N4	GV2L14	138	300
ATV610U30N4, ATV610U40N4, ATV610U55N4	GV2L16	170	300
ATV610U75N4	GV2L20	223	400
ATV610D11N4	GV2L22	327	600
	GV3L25	350	600
ATV610D15N4	GV3L32	448	700
ATV610D18N4	GV3L40	560	900
ATV610D22N4	GV3L50	700	1100
	GV3L65	910	1800
ATV610D30N4, ATV610D37N4	GV4L80	480	1800
ATV610D45N4	GV4L115	690	2500
ATV610D55N4	NSX100-MA100	600	2900
ATV610D55N4, ATV610D75N4	NSX160-MA150	1350	3200
ATV610D90N4, ATV610C11N4	NSX250-MA220	1980	4700
ATV610C13N4, ATV610C16N4	NSX400-1.3M320	1600	6300

NOTE: Verify that the minimum required prospective short-circuit current (I_{sc}) value from the table above is lower than the value estimated in the Calculation section (*see page 34*).

IEC Fuses

gG-aR Category Fuses Selection Table

Current limiting fuses can be chosen as SCPD according to the following table:

Catalog Number	Fuse gR-aR to IEC 60269-4	
	Rating	Minimum I _{sc}
380...415 Vac	(A)	(A)
ATV610U07N4	8	100
ATV610U15N4	10	100
ATV610U22N4	12,5	200
ATV610U40N4	16	200
ATV610U30N4, ATV610U55N4	20	200
ATV610U75N4	25	300
ATV610D11N4	40	500
ATV610D15N4	50	800
ATV610D18N4	63	1000
ATV610D22N4	80	1500
ATV610D30N4	100	1500
ATV610D37N4	125	2000
ATV610D45N4, ATV610D55N4	160	2500
ATV610D75N4, ATV610D90N4	200	4000
ATV610C11N4	315	6000
ATV610C13N4	350	7000
ATV610C16N4	400	9000

Chapter 3

Drive Mounting

What Is in This Chapter?

This chapter contains the following topics:

Topic	Page
Mounting Conditions	40
Derating Curves	44
Mounting Procedures	47

Mounting Conditions

Before You Begin

Conductive foreign objects, dust or liquids or damaged parts may cause parasitic voltage.

⚡ ⚠ DANGER
ELECTRIC SHOCK CAUSED BY FOREIGN OBJECTS OR DAMAGE
<ul style="list-style-type: none"> Do not use damaged products. Keep foreign objects such as chips, screws or wire clippings from getting into the product. Verify correct seat of seals and cable entries in order to avoid deposits and humidity.
Failure to follow these instructions will result in death or serious injury.

The temperature of the products described in this manual may exceed 80 °C (176 °F) during operation.

⚠ WARNING
HOT SURFACES
<ul style="list-style-type: none"> Ensure that any contact with hot surfaces is avoided. Do not allow flammable or heat-sensitive parts in the immediate vicinity of hot surfaces. Verify that the product has sufficiently cooled down before handling it. Verify that the heat dissipation is sufficient by performing a test run under maximum load conditions.
Failure to follow these instructions can result in death, serious injury, or equipment damage.

Power Drive Systems (PDS) can generate strong local electrical and magnetic fields. This can cause interference in electromagnetically sensitive devices.

⚠ WARNING
ELECTROMAGNETIC FIELDS
<ul style="list-style-type: none"> Keep persons with electronic medical implants, such as pacemakers, away from the equipment. Do not place electromagnetically sensitive devices in the vicinity of the equipment.
Failure to follow these instructions can result in death, serious injury, or equipment damage.

Attaching A Label With Safety Instructions

A label kit is provided with the drive.

Step	Action
1	Observe the safety regulations in the target country
2	Select the label suitable for the target country
3	<p>Attach the label to the front of the device so that it is clearly visible. Below is the English version. The label can vary depending on the frame size of the product.</p> <div style="text-align: center;">  </div> <p>NOTE: Products used in Canada according to CSA C22.2 no.274 must comply with the requirement defined by the Canadian Advisory council of Electrical Safety (CACES). It defines that dual language (French and English) safety labeling is required on all products for use in Canada. To fulfill this requirement, add the French language safety label on the front panel of the product.</p>

Mounting Types

This table shows the possible mounting types and the resulting IP degree of protection.

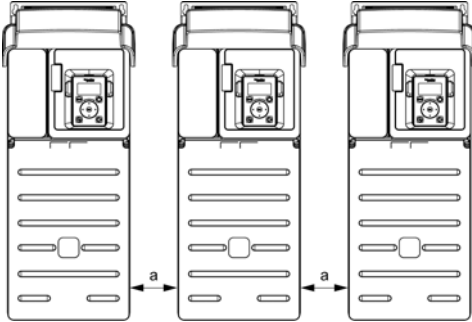
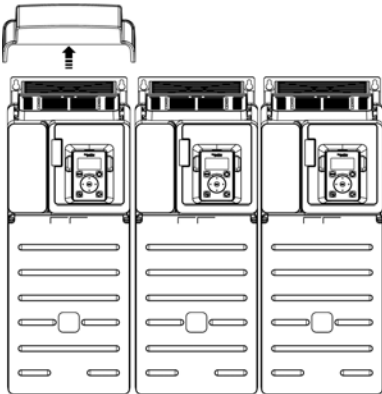
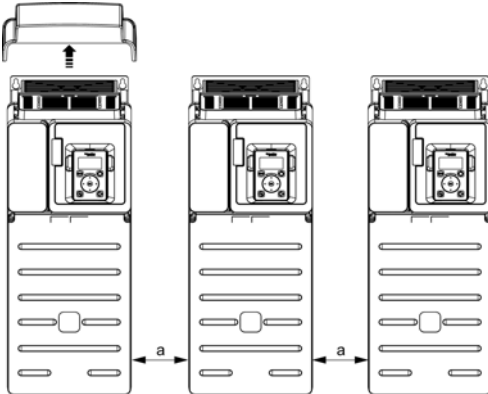
Mounting		Figure
No	Type / IP	
A	Individual IP20	 <p>Frame sizes 1, 2 and 3: $a \geq 100 \text{ mm (3.9 in.)}$ Frame sizes 4, 5 and 6: $a \geq 110 \text{ mm (4.33 in.)}$</p>
B	Side by side IP20	 <p>Frame sizes 1, 2 and 3: possible Frame sizes 4 and 5: possible, 2 drives only Frame size 6: only at ambient temperature lower than 40 °C (104 °F)</p>
C	Individual IP20	 <p>Frame sizes 1, 2 and 3: no restriction of clearance Frame sizes 4, 5 and 6: $a \geq 110 \text{ mm (4.33 in.)}$</p>

Clearances and Mounting Position - Wall Mounting

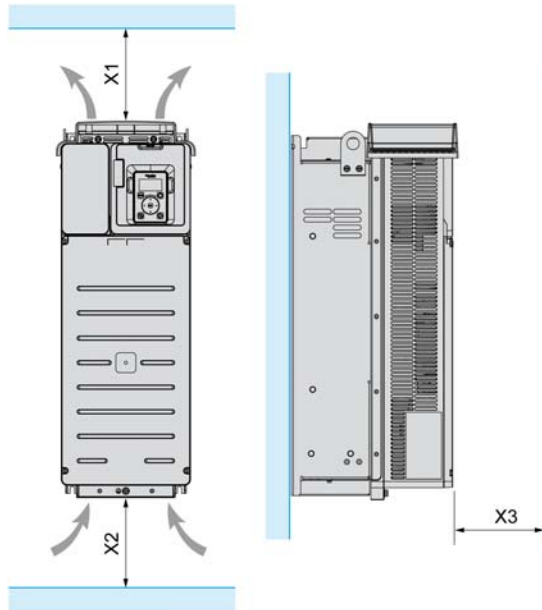

Minimum clearance regarding the drive frame size

Frame Size	X1	X2	X3
1...5	≥ 100 mm (3.94 in.)	≥ 100 mm (3.94 in.)	≥ 10 mm (0.39 in.)
6	≥ 250 mm (10 in.)	≥ 250 mm (10 in.)	≥ 100 mm (3.94 in.)

X1: free space in top of the drive

X2: free space in bottom of the drive

X3: free space in front of the drive

General Mounting Instructions

- Mount the device in a vertical position. This is required for cooling the device.
- Attach it on the mounting surface in compliance with standards, using 4 screws with captive washer according to the table given in Mounting Procedures ([see page 47](#)).
- The use of washers is required with all mounting screws.
- Tighten the fixation screws.
- Do not mount the device close to heat sources.
- Avoid environmental effects like high temperatures and high humidity as well as dust, dirt and conductive gases.
- Adhere to the minimum installation distances for required cooling.
- Do not mount the device on flammable materials.

Power Dissipated For Enclosed Drives and Required Air Flow

Catalog Number	Frame Size	Power Dissipated (1)			Minimum air flow rate required	
		Forced Cooled Area	Natural Cooled Area	Total	(m ³ /h)	(ft ³ /min)
		(W)	(W)	(W)		
ATV610U07N4	1	19	23	42	38	22
ATV610U15N4	1	40	25	65	38	22
ATV610U22N4	1	54	27	81	38	22
ATV610U30N4	1	74	29	103	38	22
ATV610U40N4	1	128	32	160	38	22
ATV610U55N4	1	171	35	205	38	22
ATV610U75N4	1	216	42	258	103	61
ATV610D11N4	2	310	54	364	103	61
ATV610D15N4	2	408	62	469	215	127
ATV610D18N4	3	410	64	474	215	127
ATV610D22N4	3	492	72	564	215	127
ATV610D30N4	4	649	91	740	240	141
ATV610D37N4	4	842	109	950	240	141
ATV610D45N4	4	1,000	121	1,121	240	141
ATV610D55N4	5	969	131	1,100	295	174
ATV610D75N4	5	1,460	177	1,637	295	174
ATV610D90N4	5	1,745	199	1,943	295	174
ATV610C11N4	6	2,060	230	2,290	600	353
ATV610C13N4	6	2,620	260	2,880	600	353
ATV610C16N4	6	3,410	300	3,710	600	353

(1) First value is the power dissipated at nominal current in the forced cooled area of the drive. The second value is the power dissipated at nominal current in the natural cooled area. If the drive is installed in a standard cabinet, the sum of both values is to be taken into account.

Derating Curves

Description

Derating curves for the nominal drive current (I_n) as a function of temperature and switching frequency. Refer to the Mounting Conditions chapter (*see page 41*) for the mounting types description.

Frame Size 1

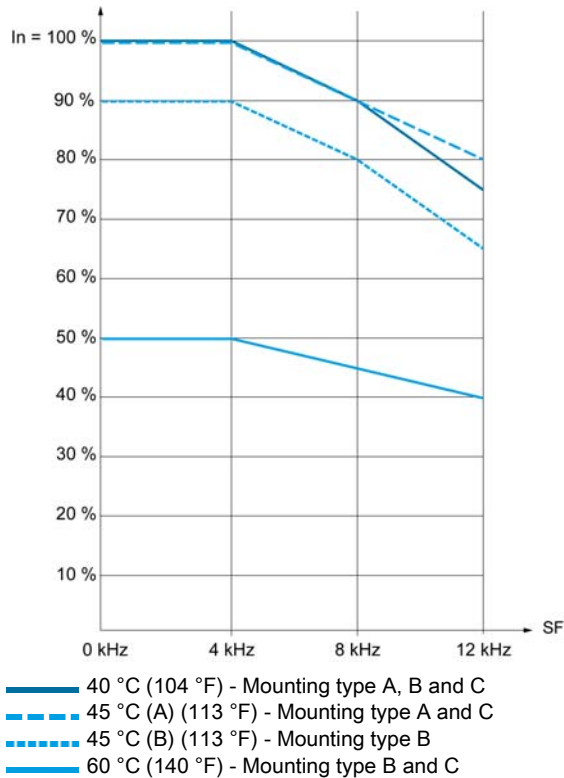

Frame Size 2

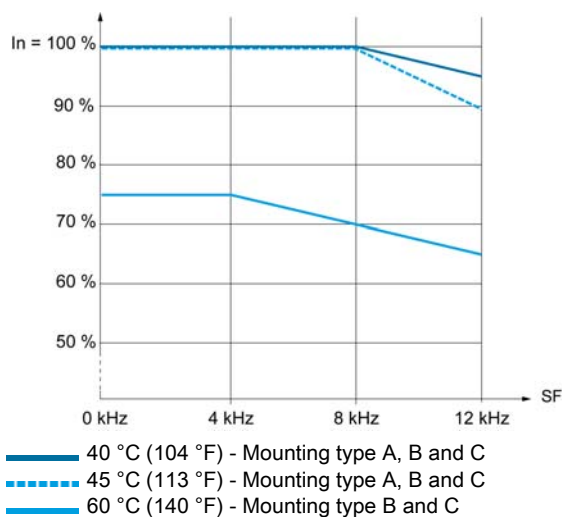

Frame Size 3

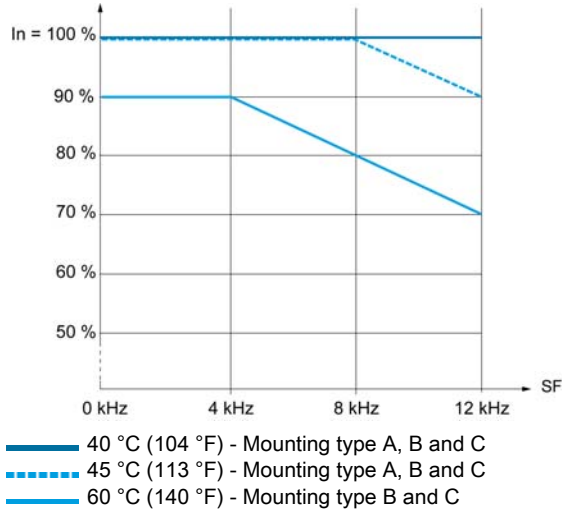

Frame Size 4

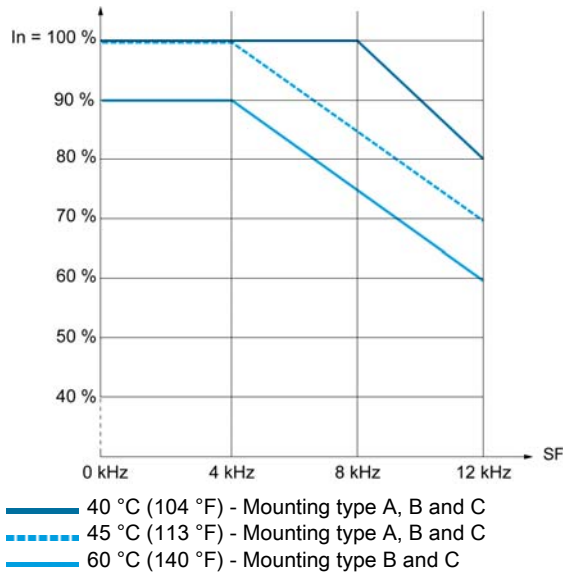

Frame Size 5

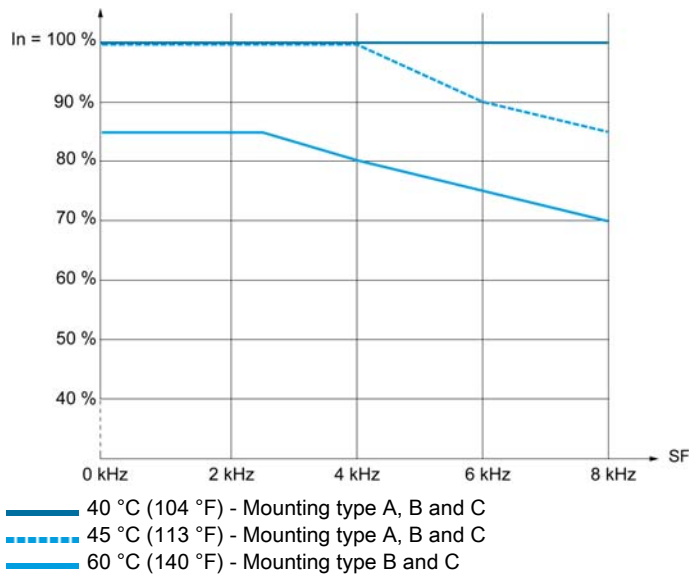

Frame Size 6

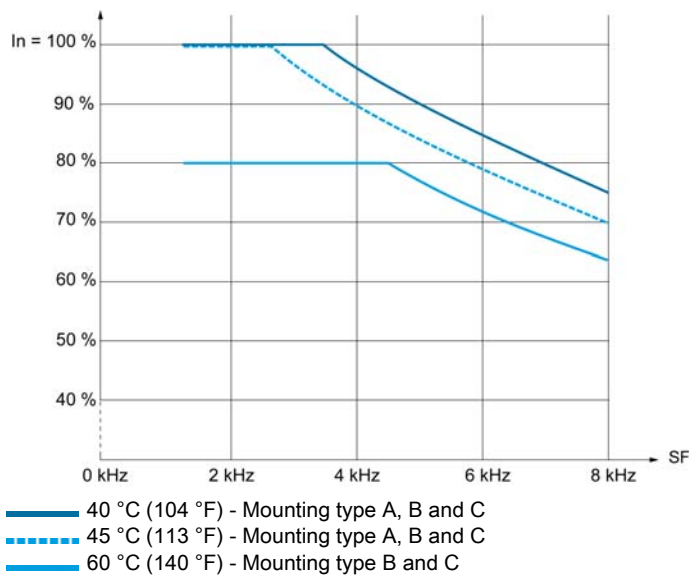

Mounting Procedures

Mounting Screws

Frame Size	Screw diameter	Hole diameter
1	5 mm (0.2 in)	6 mm (0.24 in)
2	5 mm (0.2 in)	6 mm (0.24 in)
3	5 mm (0.2 in)	6 mm (0.24 in)
4	6 mm (0.24 in)	7 mm (0.28 in)
5	8 mm (0.31 in)	9 mm (0.35 in)
6	10 mm (0.4 in)	11.5 mm (0.45 in)

Mounting Procedure For Frame Sizes 1 to 4

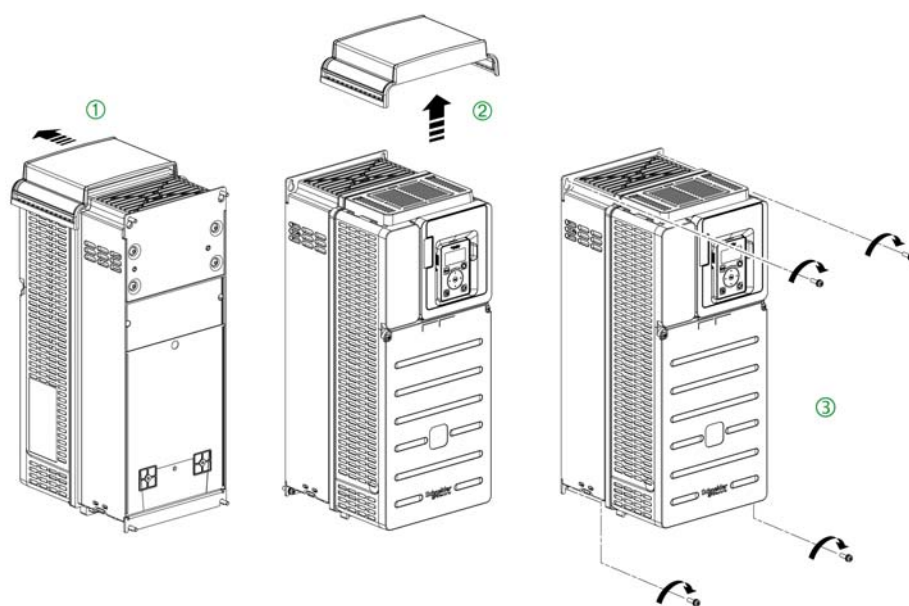

Perform the following instructions

Step	Action
1	Slide the top cover from back to front
2	Remove the top cover
3	Attach the drive the mounting surface using the M5 screws with captive washer.
4	Refit the top cover to help prevent extra parts to fall into the drive during wiring operation or if IP20 degree of protection is requested.

Mounting Frame Size 5 Drives

Mounting of the drive does not require any preliminary procedure. Just Screw the drive on the mounting surface using the M8 screws with captive washer.

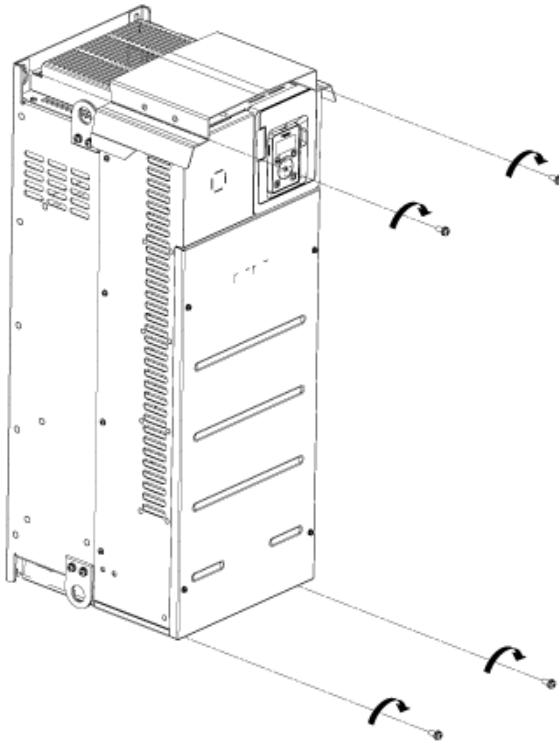

Mounting Procedure For Frame Size 6

NOTE: Due to accessible live parts on their lower part, these drives must be installed in enclosures or located behind enclosures or barriers, which comply at least with the requirements of IP2*, as per IEC61800-5-1.

Mounting the drive does not require preliminary dismantling operation. Just screw the drive on the mounting surface using the M10 screws with captive washer.

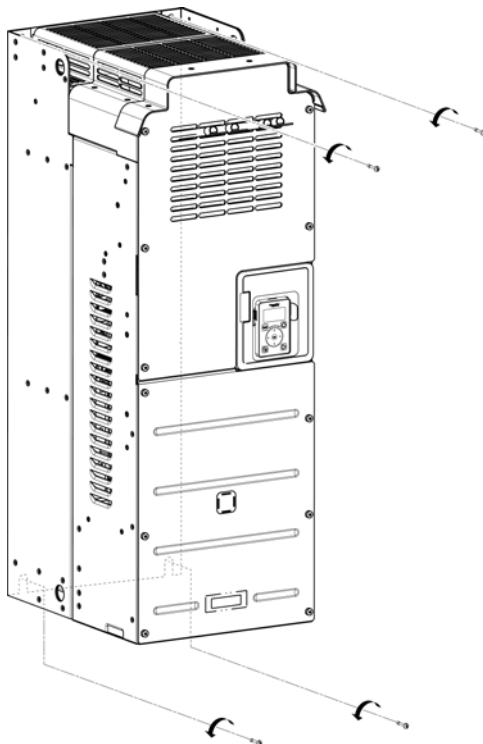

Chapter 4

Drive wiring

What Is in This Chapter?

This chapter contains the following topics:

Topic	Page
Wiring Instructions	50
Cable Length Instructions	55
General Wiring Diagrams	57
Output Relay with Inductive AC Loads	60
Output Relay with Inductive DC loads	61
Sink / Source Switch Configuration	63
Characteristics of the Power Part Terminals	64
Wiring The Power Part	67
Electromagnetic Compatibility	71
Operation on an IT or Corner Grounded System	73
Disconnecting The Built-in EMC Filter	74
Arrangement and Characteristics of Control Block Terminals and Communication and I/O Ports	77
Control Terminals Electrical Data	78
Wiring The Control Part	81

Wiring Instructions

General Instructions

The entire installation procedure must be performed without voltage present.

DANGER

HAZARD OF ELECTRIC SHOCK, EXPLOSION OR ARC FLASH

Read and understand the instructions in **Safety Information** chapter before performing any procedure in this chapter.

Failure to follow these instructions will result in death or serious injury.

Drive systems may perform unexpected movements because of incorrect wiring, incorrect settings, incorrect data or other errors.

WARNING

UNANTICIPATED EQUIPMENT OPERATION

- Carefully install the wiring in accordance with the EMC requirements.
- Do not operate the product with unknown or unsuitable settings or data.
- Perform a comprehensive commissioning test.

Failure to follow these instructions can result in death, serious injury, or equipment damage.

Unsuitable settings or unsuitable data or unsuitable wiring may trigger unintended movements, trigger signals, damage parts and disable monitoring functions.

WARNING

UNANTICIPATED EQUIPMENT OPERATION

- Only start the system if there are no persons or obstructions in the zone of operation.
- Verify that a functioning emergency stop push-button is within reach of all persons involved in the operation.
- Do not operate the drive system with unknown settings or data.
- Verify that the wiring is appropriate for the settings.
- Never modify a parameter unless you fully understand the parameter and all effects of the modification.
- When commissioning, carefully run tests for all operating states, operating conditions and potential error situations.
- Anticipate movements in unintended directions or oscillation of the motor.

Failure to follow these instructions can result in death, serious injury, or equipment damage.

DANGER

HAZARD OF FIRE OR ELECTRIC SHOCK

- Wire cross sections and tightening torques must comply with the specifications provided in this document
- If you use flexible multi-wire cables for a connection with a voltage higher than 25 Vac, you must use ring type cable lugs or wire ferrules, depending on the connection.

Failure to follow these instructions will result in death or serious injury.

The product has a leakage current greater than 3.5 mA. If the protective ground connection is interrupted, a hazardous touch current may flow if the product is touched.

⚡ ⚠ DANGER

ELECTRIC SHOCK CAUSED BY HIGH LEAKAGE CURRENT

- Verify compliance with all local and national electrical code requirements as well as all other applicable regulations with respect to grounding of the entire drive system.

Failure to follow these instructions will result in death or serious injury.

⚡ ⚠ DANGER

INSUFFICIENT PROTECTION AGAINST OVERCURRENTS CAN CAUSE FIRE OR EXPLOSION

- Use properly rated overcurrent protection devices.
- Use the fuses/circuit breakers specified.
- Do not connect the product to a supply mains whose prospective short circuit current rating (current that flows during a short circuit) exceeds the specified maximum permissible value.
- When rating the upstream mains fuses and the cross sections as well as the lengths of the mains cables, take into account the minimum required prospective short-circuit current (Isc). Refer to the Upstream Protection Device section.
- If the minimum required prospective short-circuit current (Isc) is not available, apply the instructions given in the section below.

Failure to follow these instructions will result in death or serious injury.

The specified maximum permissible values and products for IEC compliance are specified in the catalog.

Cable Characteristics

Only use cables with insulator heat resistance of 75°C (167°F) min.

If you are using cables longer than 150 m (492 ft) between the drive and the motor, add output filters (for more details refer to the catalog).

Use a shielded cable to meet the requirements of Category C2 or C3 according to the standard IEC 61800-3, except when using a sinus filter. In this case, the use of a non-shielded motor cable is possible.

To limit the currents in common mode, use common mode output filters (ferrite) in order to reduce the circulating currents in the motor windings.

Standard linear capacity cables can be used with Altivar Process. Use of cables with lower linear capacity could increase cable length performances.

The overvoltage limitation function **[Motor surge limit.] 5 V L** enables you to increase the cable length while decreasing the torque performances (refer to Programming manual [\(see page 9\)](#))

Power Part Cables Stripping lengths

Catalog Number and Frame Size [°]		Cable Stripping Length
		Input and Output mm (in.)
ATV610U07N4...U75N4	[1]	11 ± 1 (0.43 ± 0.04)
ATV610UD11N4, D15N4	[2]	11 ± 1 (0.43 ± 0.04)
ATV610D18N4, D22N4	[3]	20 ± 2 (0.79 ± 0.08)
ATV610D30N4...D45N4	[4]	26 ± 2 (1.02 ± 0.08)
ATV610D55N4...D90N4	[5]	32 ± 3 (1.26 ± 0.12)

⚠ WARNING

UNANTICIPATED EQUIPMENT OPERATION

Verify that the digital and analog inputs and outputs are wired with the shielded, twisted-pair cables specified in the present manual.

Failure to follow these instructions can result in death, serious injury, or equipment damage.

- Keep the control circuits away from the power cables. For digital and analog inputs/outputs, use shielded twisted cables with a pitch of 25...50 mm (1 in. and 2 in.)
- It is advisable to use cable ends, available on www.schneider-electric.com.

Residual Current Device

Direct current can be introduced in the protective ground conductor of this drive. If a residual current device (RCD / GFCI) or a residual current monitor (RCM) is used for additional protection against direct or indirect contact, the following specific types must be used.

WARNING

DIRECT CURRENT CAN BE INTRODUCED INTO THE PROTECTIVE GROUND CONDUCTOR

- Use a Type A Residual Current Device (RCD / GFCI) or a Residual Current Monitor (RCM) for single-phase drives connected to a phase and to the neutral conductor.
- Use a Type B Residual Current Device (RCD / GFCI) or a Residual Current Monitor (RCM) that has approval for use with frequency inverters and is sensitive to all types of current for three-phase devices and for single-phase devices not connected to a phase and the neutral conductor.

Failure to follow these instructions can result in death, serious injury, or equipment damage.

Further conditions for use of a residual current device:

- The drive has an increased leakage current at the moment power is applied. Use a residual current device (RCD / GFCI) or a residual current monitor (RCM) with a response delay.
- High-frequency currents must be filtered.

Due to high leakage current in standard operation, it is advisable to choose at least a 300 mA device.

If the installation requires a residual current device less than 300 mA, it can be possible to use a device lower than 300 mA by removing the screws according to the instructions given in the Operation on an IT System section (*see page 73*).

If the installation includes several drives, provide one residual current device per drive.

Equipment Grounding

NOTICE

DESTRUCTION DUE TO INCORRECT WIRING

- Before switching on and configuring the product, verify that it is properly wired.

Failure to follow these instructions can result in equipment damage.

DANGER

ELECTRIC SHOCK CAUSED BY INSUFFICIENT GROUNDING

- Verify compliance with all local and national electrical code requirements as well as all other applicable regulations with respect to grounding of the entire drive system.
- Ground the drive system before applying voltage.
- The cross section of the protective ground conductor must comply with the applicable standards.
- Do not use conduits as protective ground conductors; use a protective ground conductor inside the conduit.
- Do not consider cable shields to be protective ground conductors.

Failure to follow these instructions will result in death or serious injury.

Tighten the grounding screws according to the instructions given in the Ground Cables section (*see page 64*).

Connection Instructions

The product has a leakage current greater than 3.5 mA. If the protective ground connection is interrupted, a hazardous touch current may flow if the product is touched.

⚡ ⚠ DANGER

ELECTRIC SHOCK CAUSED BY HIGH LEAKAGE CURRENT

- Verify compliance with all local and national electrical code requirements as well as all other applicable regulations with respect to grounding of the entire drive system.

Failure to follow these instructions will result in death or serious injury.

⚡ ⚠ DANGER

INSUFFICIENT PROTECTION AGAINST OVERCURRENTS CAN CAUSE FIRE OR EXPLOSION

- Use properly rated overcurrent protection devices.
- Use the fuses/circuit breakers specified.
- Do not connect the product to a supply mains whose prospective short circuit current rating (current that flows during a short circuit) exceeds the specified maximum permissible value.
- When rating the upstream mains fuses and the cross sections as well as the lengths of the mains cables, take into account the minimum required prospective short-circuit current (Isc). Refer to the Upstream Protection Device section.
- If the minimum required prospective short-circuit current (Isc) is not available, apply the instructions given in the section below.

Failure to follow these instructions will result in death or serious injury.

The specified maximum permissible values and products for IEC compliance are specified in the catalog.

- Ensure that the resistance to Ground is 1 Ohm or less.
- When grounding several drives, you must connect each one directly, as shown in the above figure.
- Do not loop Ground cables or connect them in series.

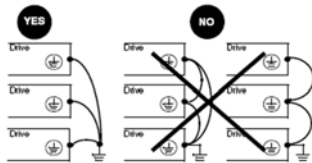

Cable Length Instructions

Long Cable Lengths Consequences

When drives are used with motors, a combination of fast switching transistors and long motor cables can even cause peak voltages up to twice the DC link voltage. This high peak voltage can cause premature aging of motor winding insulation which leads to motor breakdown.

The overvoltage limitation function will enable to increase the cable length while decreasing the torque performances.

Length Of Motor Cables

Because of the permitted mains disturbances, the allowed overvoltages at the motor, the occurring bearing currents and the permitted heat losses the distance between inverter and motor(s) is limited.

The maximum distance heavily depends on the used motors (insulation material), the type of motor cable used (shielded/unshielded), the cable laying (cable channel, underground installation...) as well as from the used options.

Dynamic Voltage Load Of The Motor

Overvoltages at the motor terminals result from reflection in the motor cable. Basically the motors are stressed with measurable higher voltage peaks from a motor cable length of 10 m. With the length of the motor cable also the value of overvoltage increases.

The steep edges of the switching impulses at the output side of the frequency inverter lead to a further load of the motors. The slew rate of the voltage is typically over 5 kV/μs but it decreases with the length of the motor cable

Load of the motor with overvoltage and slew rate when using conventional drive

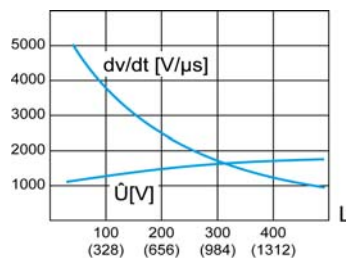

L Length of motor cables in meters (feet)

Corrective Actions Overview

A number of simple measures can be taken to help enhance the motor life time:

- Specification of a motor designed for speed drive applications (IEC60034-25 B or NEMA MG1 Part 31 should be prescribed).
- Specification of drives that integrate voltage reflection superimposition software suppression. Refer to **[Volt surge limit. opt] 5 o P** parameter in the Programming manual (*see page 9*).
- Reduce to a minimum the distance between motor and drive.
- Use unshielded cables.
- Reduce the drive switching frequency (a reduction to 2.5 kHz is advisable.)

Preventive Measures Suitable for Wall Mounting Drives According to IEC60034-25

The preventive measures will depend on motor characteristics and cable length.

Motor cable length (unshielded cable)	Motor conforming to IEC60034-25	Motor NOT-conforming to IEC60034-25
1 m (3 ft) < L < 50 m (164 ft)	Filter not required	dV/dt filter
50 m (164 ft) < L < 100 m (328 ft)	Filter not required	Sinus filter
100 m (328 ft) < L < 300 m (984 ft)	Filter not required	Sinus filter
300 m (984 ft) < L < 500 m (1640 ft)	dV/dt filter	Sinus filter
500 m (1640 ft) < L < 1000 m (3281 ft)	Sinus filter	Sinus filter

NOTE: When calculating cable lengths for the purpose of guarding against these overvoltage situations, a shielded cable should count as twice the length of an unshielded cable. For example, if a shielded cable is 100 m (328 ft) in actual length, it should be considered to be equal to a 200 m (656 ft) length standard cable in the calculation.

Additional Information

Further detailed technical information is available in the following white paper *An Improved Approach for Connecting VSD and Electric Motors* ([998-2095-10-17-13AR0 EN](#)) available on www.schneider-electric.com.

General Wiring Diagrams

Control Block Wiring Diagram

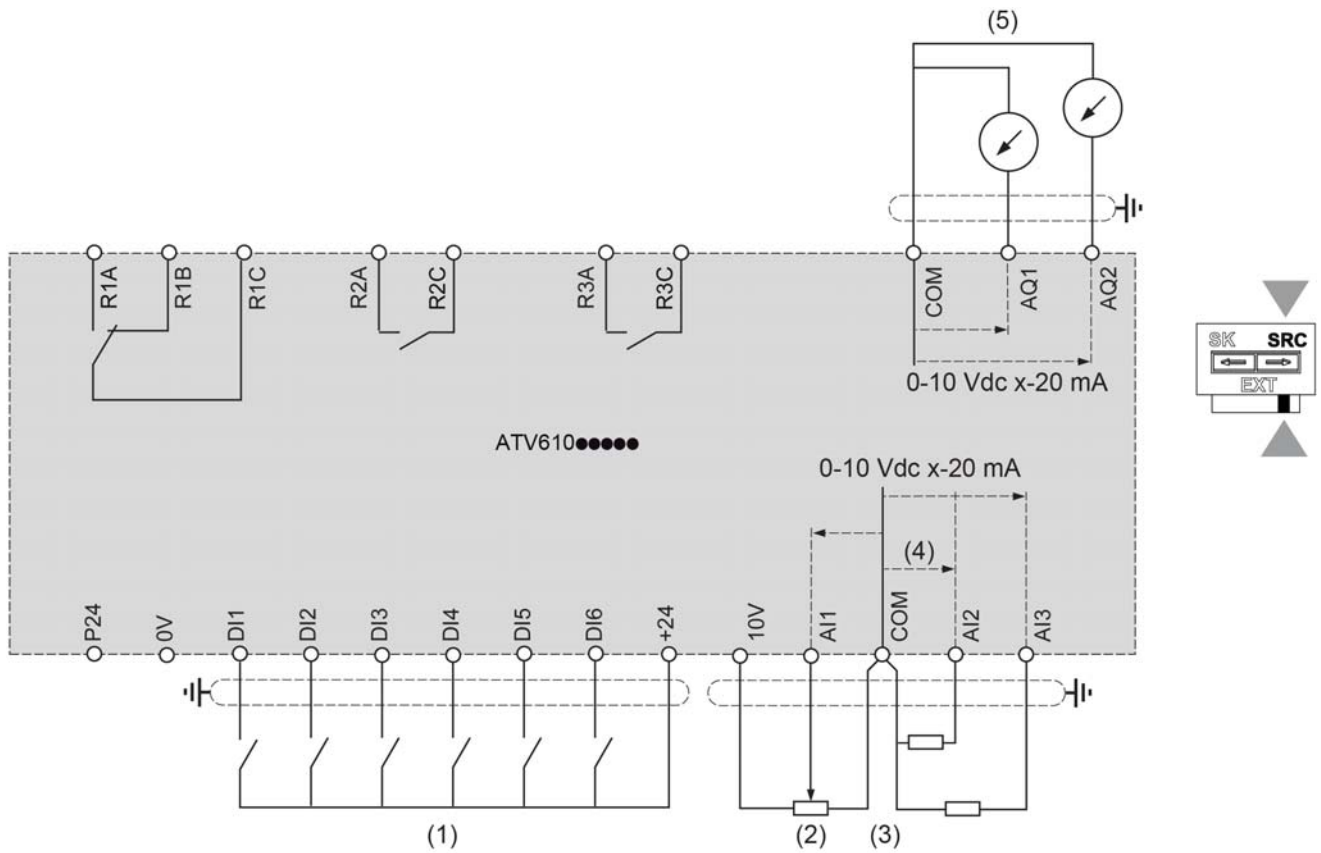

(1) Digital Inputs - Shielding instructions are given in the Electromagnetic Compatibility section ([see page 71](#)).

(2) Reference potentiometer (ex. SZ1RV1002)

(3) Analog inputs

(4) -10...10 Vdc

(5) Analog outputs

Three-phase Power Supply - Diagram With Line Contactor

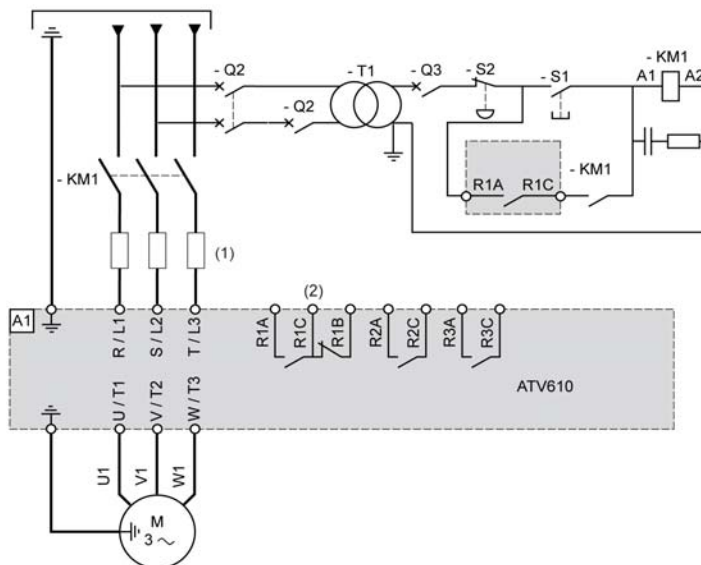

- (1) Line choke (if used).
- (2) Use relay output R1 set to operating state Fault to switch Off the product once an error is detected.

Three-phase Power Supply - Diagram With Downstream Contactor

If a Run command is executed while the downstream contactor between the drive and the motor is still open, there may be residual voltage at the output of the drive. This can cause an incorrect estimation of the motor speed when the contacts of the downstream contactor are closed. This incorrect estimation of the motor speed can lead to unanticipated equipment operation or to equipment damage.

In addition, there may be overvoltage at the output of the drive if the power stage is still enabled when the downstream contactor between the drive and the motor opens.

⚠ WARNING

UNANTICIPATED EQUIPMENT OPERATION OR EQUIPMENT DAMAGE

If a downstream contactor is used between the drive and the motor, verify the following:

- The contacts between the motor and the drive must be closed before a Run command is executed.
- The power stage must not be enabled when the contacts between the motor and the drive open.

Failure to follow these instructions can result in death, serious injury, or equipment damage.

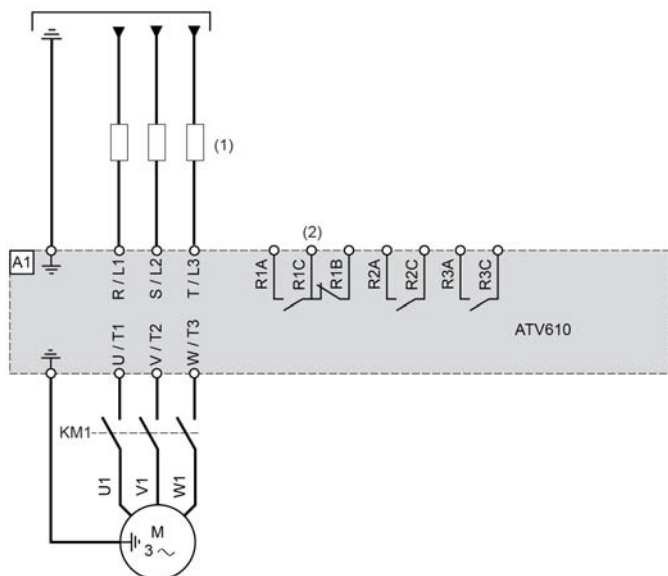

- (1) Line choke (if used)
- (2) Use relay output R1 set to operating state Fault to switch Off the product once an error is detected.

Sensor Connection

It is possible to connect either 1 or 3 sensors on terminals AI2 or AI3.

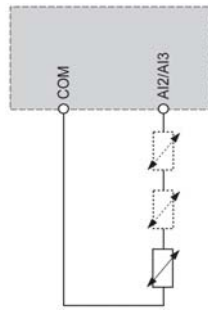

Output Relay with Inductive AC Loads

General

The AC voltage source must be of overvoltage category II (OVC II) according to IEC61800-5-1.

If it is not the case an insulation transformer must be used.

Contactors with AC Coil

If controlled by relay, a resistor-capacitor (RC) circuit must be connected in parallel to the coil of the contactor, as shown on the drawing below.

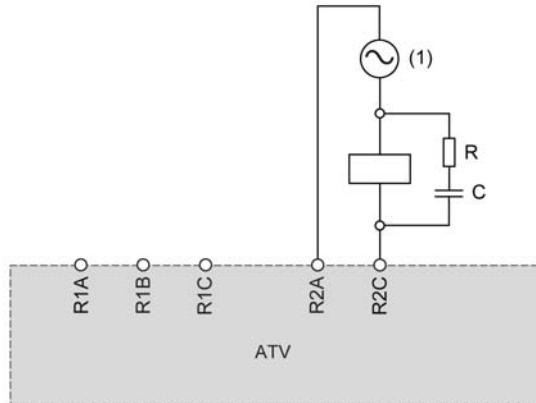

(1) AC 250 Vac maxi.

Schneider Electric AC contactors have a dedicated area on the housing to plug easily the RC device. Refer to the Motor control and protection components catalog [MKTED210011EN](#) available on [se.com](#) to find the RC device to be associated with the contactor used.

Example: With a 48 Vac source, contactors [LC1D09E7](#) or [LC1DT20E7](#) have to be used with [LAD4RCE](#) voltage suppression device.

Other Inductive AC Loads

For other inductive AC loads...

- Use an auxiliary contactor connected on drive to control the load.
Example: with a 48 Vac source, auxiliary contactors [CAD32E7](#) or [CAD50E7](#) with [LAD4RCE](#) voltage suppression device.
- When using a third party inductive AC load, request the supplier to provide information on the voltage suppression device, in order to avoid overvoltage above 375 V during relay opening.

Output Relay with Inductive DC loads

Contactors with DC Coil

If controlled by relay, a bidirectional transient voltage suppression (TVS) diode, also called transil, must be connected in parallel to the coil of the contactor, as shown on the drawing below.

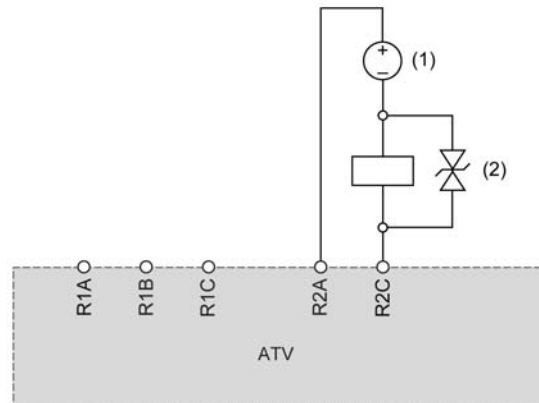

- (1) DC 30 Vdc maxi.
- (2) TVS diode

Schneider Electric contactors with DC coil include the TVS diode. No additional device is required.

Refer to the Motor control and protection components catalogue [MKTED210011EN](#) available on [se.com](#) for more information.

Other Inductive DC Loads

Other inductive DC loads without embedded TVS diode must use one of the following voltage suppression device:

- A bidirectional TVS device as shown on the drawing above, defined by...
 - TVS break-down voltage greater than 35 Vdc,
 - TVS clamping voltage $V(\text{TVS})$ less than 50 Vdc
 - TVS peak power dissipation greater than load rated current, $I(\text{load}) \times V(\text{TVS})$.
Example: with $I(\text{load}) = 0.9 \text{ A}$ and $V(\text{TVS}) = 50 \text{ Vdc}$, TVS peak power must be greater than 45 W
 - TVS average power dissipation greater than the value calculated by the following $0.5 \times I(\text{load}) \times V(\text{TVS}) \times \text{load time constant} \times \text{number of operation per second}$.
Example: with $I(\text{load}) = 0.9 \text{ A}$ and $V(\text{TVS}) = 50 \text{ Vdc}$, load time constant = 40 ms (load inductance divided by load resistance) and 1 operation every 3 s, the TVS average power dissipation must be greater than $0.5 \times 0.9 \times 50 \times 0.04 \times 0.33 = 0.3 \text{ W}$.
- A fly-back diode as shown in the drawing below.

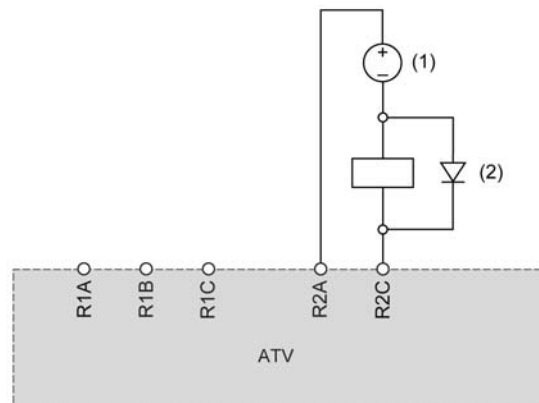

- (1) DC 30 Vdc maxi.
- (2) Flyback diode

The diode is a polarized device. The fly-back diode must be defined by...

- a reverse voltage greater than 100 Vdc,
- a rated current greater than two times the load rated current,
- a thermal resistance: junction to ambient temperature (in K/W) less than $90 / (1.1 \times I(\text{load}))$ to operate at maximum 60°C (140°F) ambient temperature.

Example: with $I(\text{load}) = 1.5 \text{ A}$, select a 100 V, 3 A rated current diode with a thermal resistance from junction to ambient less than $90 / (1.1 \times 1.5) = 54.5 \text{ K/W}$.

Using a flyback diode, the relay opening time will be longer than with a TVS diode.

NOTE: Use diodes with leads for easy wiring and keep at least 1 cm (0.39 in.) of leads at each side of the case of the diode for a correct cooling.

Sink / Source Switch Configuration

⚠ WARNING

UNANTICIPATED EQUIPMENT OPERATION

- If the drive is set to **SK** or **EXT**, do not connect the **0 V** terminal to ground or to protective ground.
- Verify that accidental grounding of digital inputs configured for sink logic, caused, for example, by damage to the signal cables, cannot occur.
- Follow all applicable standards and directives such as NFPA 79 and EN 60204 for proper control circuit grounding practices.

Failure to follow these instructions can result in death, serious injury, or equipment damage.

The switch is used to adapt the operation of the logic inputs to the technology of the programmable controller outputs. To access the switch, follow the Access to control Terminals procedure (*see page 81*). The switch is located below the control terminals (*see page 77*).

- Set the switch to Source (factory setting) if using PLC outputs with PNP transistors.
- Set the switch to Ext if using PLC outputs with NPN transistors.

Switch Set to SRC (Source) Position Using the Output Power Supply for the Digital Inputs

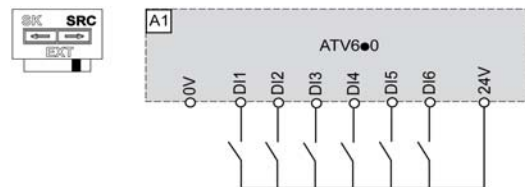

Switch Set to SK (Sink) Position Using the Output Power Supply for the Digital Inputs

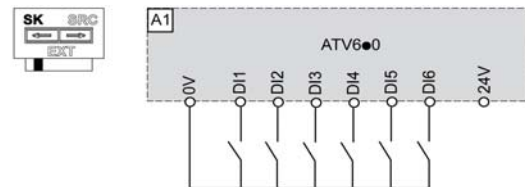

Switch Set to EXT Position Using an External Power Supply for the DIs

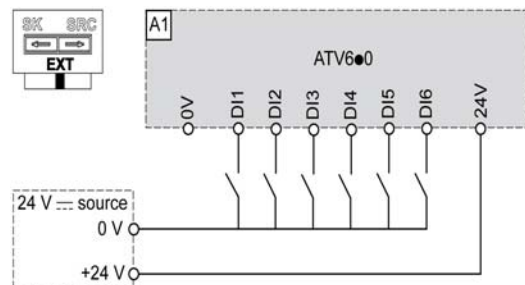

Characteristics of the Power Part Terminals

Ground Cables

Ground cable cross sections of input and output ground cables are the same as those given for the input and output cables. Minimum cross section of protective ground cable is 10 mm² (AWG 8) and 16 mm² (AWG 6) for AL cable.

Tightening torques according to frame size

- Frame sizes 1...3: 2.5 N·m (22.1 lb.in)
- Frame size 4: 12 N·m (106.2 lb.in)
- Frame size 5: 25 N·m (221.3 lb.in)
- Frame size 6:
 - ①: 27 N·m (239 lb.in)
 - ②: 13.5 N·m (119.5 lb.in)

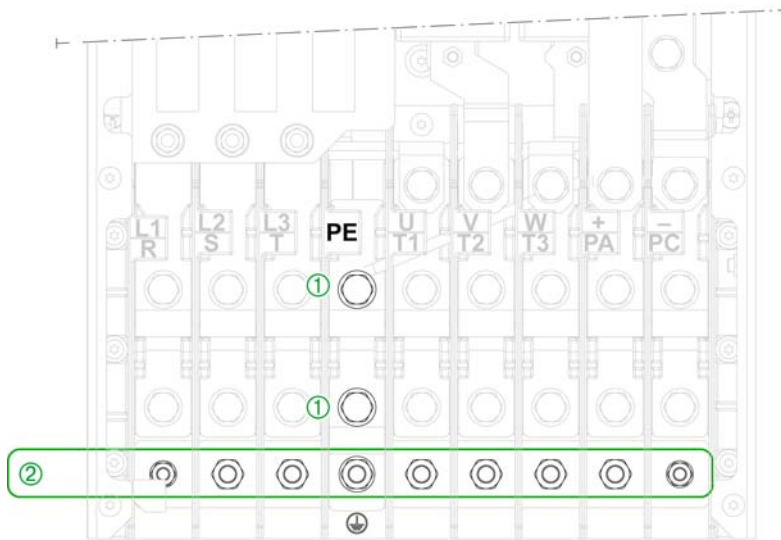

Description of the Power Terminals

Terminal	Function
PE or ⚡	Ground connection terminal
R/L1 S/L2 T/L3	AC supply mains
U/T1 V/T2 W/T3	Outputs to the motor

Frame Size 1

ATV610	Supply Terminals (L1, L2, L3)			Output Terminals (U, V, W)		
	Wire Cross Section		Tightening Torque	Wire Cross Section		Tightening Torque
	Minimum	Maximum (*)		Minimum	Maximum (*)	
	mm ² (AWG)	mm ² (AWG)	Rated	mm ² (AWG)	mm ² (AWG)	Rated
U07N4 to U55N4	1.5 (16)	6 (10)	1.3 (11.5)	1.5 (16)	6 (10)	1.3 (11.5)
U75N4	2.5 (14)	6 (10)	1.3 (11.5)	2.5 (14)	6 (10)	1.3 (11.5)

Only use cables with solid wires or rigid stranded wires.
(*) Maximum cross section of the terminals

Frame Size 2

ATV610	Supply Terminals (L1, L2, L3)			Output Terminals (U, V, W)		
	Wire Cross Section		Tightening Torque	Wire Cross Section		Tightening Torque
	Minimum	Maximum (*)	Rated	Minimum	Maximum (*)	Rated
	mm ² (AWG)	mm ² (AWG)	N·m (lb.in)	mm ² (AWG)	mm ² (AWG)	N·m (lb.in)
D11N4	4 (12)	10 (8)	1.5 (13.3)	4 (12)	10 (8)	1.5 (13.3)
D15N4	6 (10)	10 (8)	1.5 (13.3)	6 (10)	10 (8)	1.5 (13.3)
Only use cables with solid wires or rigid stranded wires. (*) Maximum cross section of the terminals						

Frame Size 3

ATV610	Supply Terminals (L1, L2, L3)			Output Terminals (U, V, W)		
	Wire Cross Section		Tightening Torque	Wire Cross Section		Tightening Torque
	Minimum	Maximum (*)	Rated	Minimum	Maximum (*)	Rated
	mm ² (AWG)	mm ² (AWG)	N·m (lb.in)	mm ² (AWG)	mm ² (AWG)	N·m (lb.in)
D18N4, D22N4	10 (8)	16 (6)	2.5 (22.1)	10 (8)	16 (6)	2.5 (22.1)
Only use cables with solid wires or rigid stranded wires. (*) Maximum cross section of the terminals						

Frame Size 4

ATV610	Supply Terminals (L1, L2, L3)			Output Terminals (U, V, W)		
	Wire Cross Section		Tightening Torque	Wire Cross Section		Tightening Torque
	Minimum	Maximum (*)	Rated	Minimum	Maximum (*)	Rated
	mm ² (AWG)	mm ² (AWG)	N·m (lb.in)	mm ² (AWG)	mm ² (AWG)	N·m (lb.in)
D30N4	16 (6)	50 (1-1/0)	12 (106.2)	16 (6)	50 (1-1/0)	12 (106.2)
D37N4	25 (4)	50 (1-1/0)	12 (106.2)	25 (4)	50 (1-1/0)	12 (106.2)
D45N4	35 (2)	50 (1-1/0)	12 (106.2)	35 (2)	50 (1-1/0)	12 (106.2)
Only use cables with rigid stranded wires. (*) Maximum cross section of the terminals						

Frame Size 5

ATV610	Supply Terminals (L1, L2, L3)			Output Terminals (U, V, W)		
	Wire Cross Section		Tightening Torque	Wire Cross Section		Tightening Torque
	Minimum	Maximum (*)	Rated	Minimum	Maximum (*)	Rated
	mm ² (AWG)	mm ² (AWG)	N·m (lb.in)	mm ² (AWG)	mm ² (AWG)	N·m (lb.in)
D55N4	50 (1-1/0)	120 (4/0)	25 (221.3)	50 (1-1/0)	120 (4/0)	25 (221.3)
D75N4	70 (2/0)	120 (4/0)	25 (221.3)	70 (2/0)	120 (4/0)	25 (221.3)
D90N4	95 (3/0)	120 (4/0)	25 (221.3)	95 (3/0)	120 (4/0)	25 (221.3)
Only use cables with rigid stranded wires. (*) maximum cross section of the terminals. (*) Maximum cross section of the terminals						

Frame Size 6

NOTE:

- If used with ring tongue: selection criteria are compatible with screw M10, width 24 mm (0.94 in.), following DIN 46234.
- If used with lugs: selection criteria are compatible with standard cable lug according to DIN 46234. You may also use lug kit DZ2FH6 and DZ2FH1 available on schneider-electric.com

ATV610	Supply Terminals (L1, L2, L3)			Output Terminals (U, V, W)		
	Wire Cross Section		Tightening Torque	Wire Cross Section		Tightening Torque
	Minimum	Maximum (*)	Rated	Minimum	Maximum (*)	Rated
	mm ²	mm ²	N·m	mm ²	mm ²	N·m
C11N4	2 x 50	3 x 120	27	2 x 50	3 x 120	27
C13N4	2 x 70	3 x 120	27	2 x 70	3 x 120	27
C16N4	2 x 95	3 x 120	27	2 x 95	3 x 120	27

(*) Maximum cross section of the terminals

Wiring The Power Part

Access To The Terminals For Frame Size 1...3

⚠ ⚠ **DANGER**

HAZARD OF ELECTRIC SHOCK, EXPLOSION OR ARC FLASH

Read and understand the instructions in **Safety Information** chapter before performing any procedure in this chapter.

Failure to follow these instructions will result in death or serious injury.

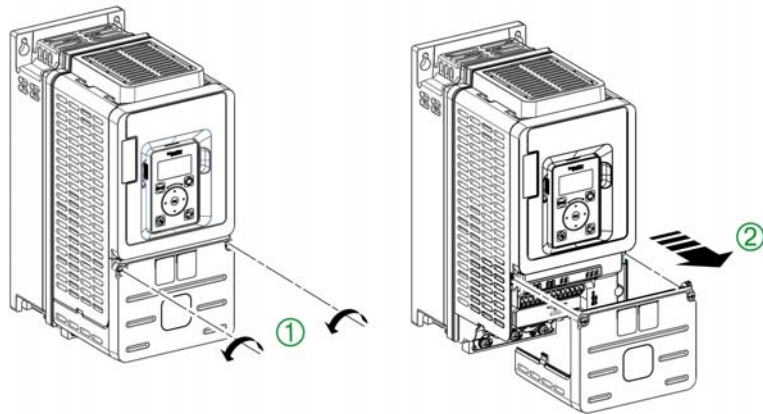

Apply the following instructions to access the terminals on **frame size 3** drives

Step	Action
1	Unscrew the 2 screws attaching the housing
2	Remove the front cover
3	Refit the front cover on completion of wiring. Tighten the screws to 1.5 N•m / 13.3 lb-in.

Frame Sizes 1 and 2 Cable Path

Wire the power cables as shown below.

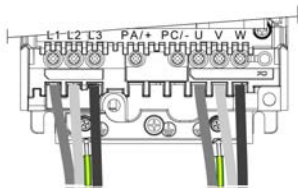

Frame Size 3 Cable Path

Wire the power cables as shown below.

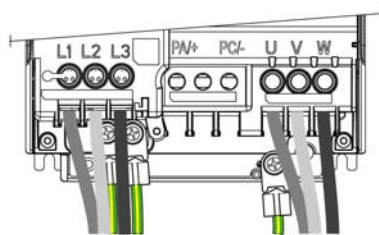

Access To The Terminals For Frame Sizes 4 and 5

⚠ ⚠ DANGER

HAZARD OF ELECTRIC SHOCK, EXPLOSION OR ARC FLASH

Read and understand the instructions in **Safety Information** chapter before performing any procedure in this chapter.

Failure to follow these instructions will result in death or serious injury.

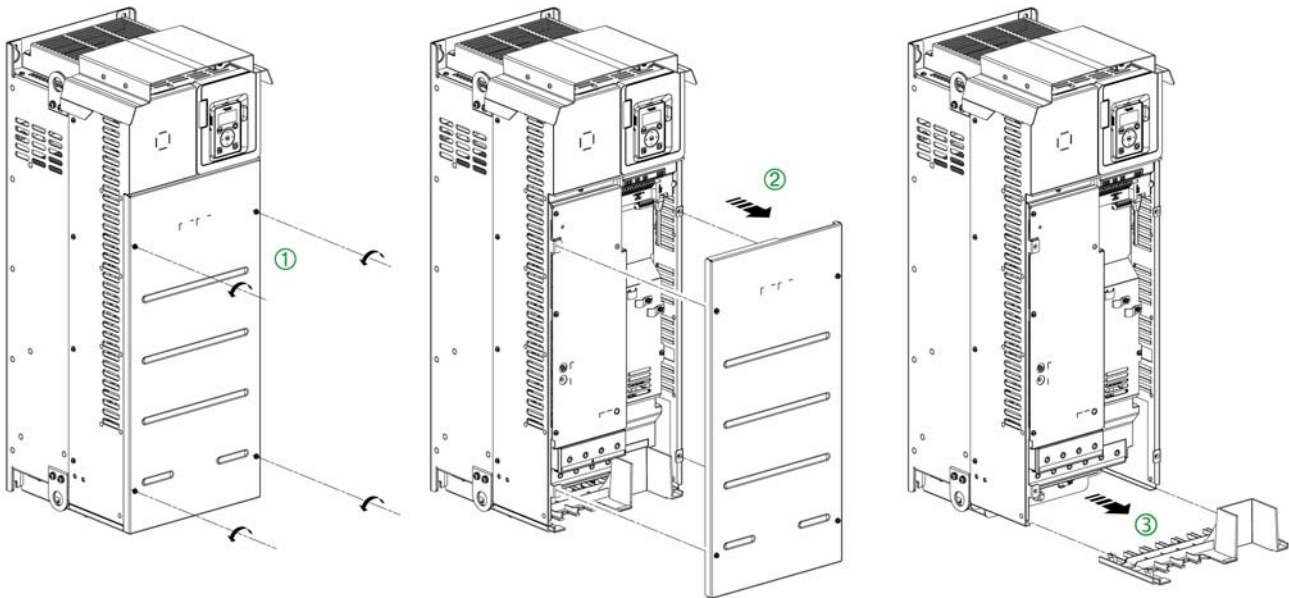

Apply the following instructions to the terminals on **frame sizes 4 and 5** drives

Step	Action
1	Unscrew the 4 screws attaching the front cover
2	Remove the front cover
3	Remove the power terminal cover
4	<p>On completion of wiring...</p> <ul style="list-style-type: none"> ● Refit the power terminal cover ● Refit the front cover <p>Tighten the front cover screws to...</p> <ul style="list-style-type: none"> ● 1.1 N•m / 9.7 lb-in for frame size 4 ● 2.6 N•m / 23 lb-in for frame size 5

Frame Size 4 And 5 Cable Path

Wire the power cables as shown below.

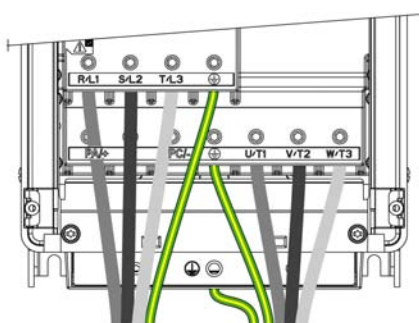

Access To The Terminals - Frame Size 6

⚠ ⚠ DANGER

HAZARD OF ELECTRIC SHOCK, EXPLOSION OR ARC FLASH

Read and understand the instructions in **Safety Information** chapter before performing any procedure in this chapter.

Failure to follow these instructions will result in death or serious injury.

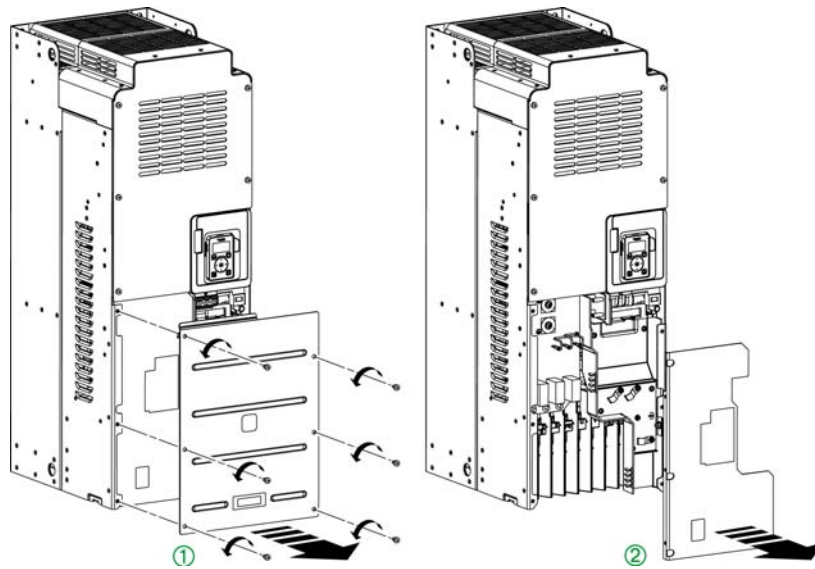

Apply the following instructions to access the terminals on **frame size 6** drives

Step	Action
1	Unscrew the 6 screws attaching the bottom front cover and remove it
2	Remove the terminal cover
3	Refit the front cover on completion of wiring. Tighten the screws to 3.3 N•m / 29.3 lb-in.

Frame Size 6 Cable Path

NOTE: Due to accessible live parts on their lower part, these drives should be installed in enclosures or located behind enclosures or barriers, which comply at least with the requirements of IP2•, as per IEC61800-5-1.

Use 1 or 2 connection cables per terminal, depending on the cable characteristics. Refer to standard IEC 60364-5-52 for cable selection. Permissible cable cross sections are given in

For 2 connection cable wiring:

Step	Action
1	Connect the first cable on the lower terminal
2	Connect the other cable on the upper terminal

For 2 cable connection, wire the power cables as shown below.

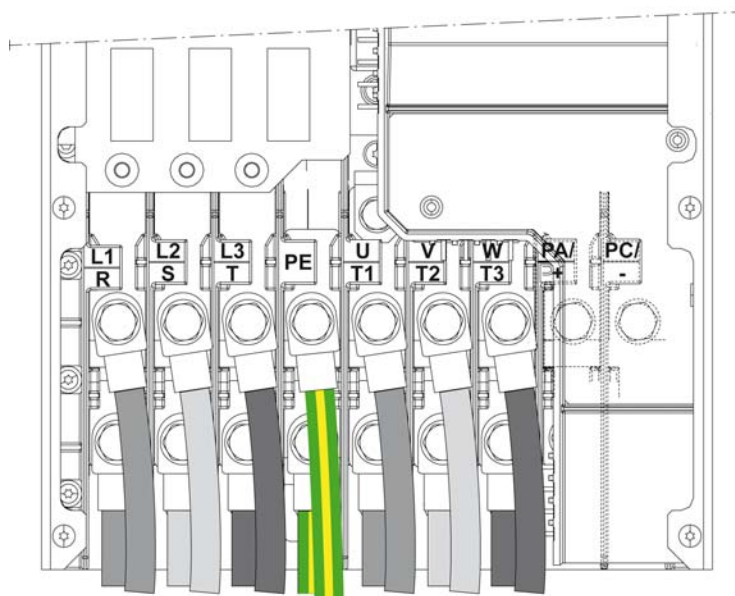

NOTE: A conduit box is available as an option. It enables an IP21 degree of protection at the bottom side of the drive. See www.schneider-electric.com

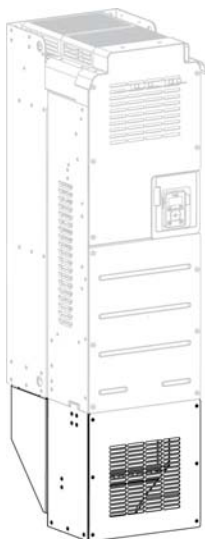

Electromagnetic Compatibility

Limit Values

This product meets the EMC requirements according to the standard IEC 61800-3 if the measures described in this manual are implemented during installation.

 WARNING
RADIO INTERFERENCE In a domestic environment this product may cause radio interference in which case supplementary mitigation measures may be required. Failure to follow these instructions can result in death, serious injury, or equipment damage.

EMC requirements for the control cabinet

EMC measures	Objective
Use mounting plates with good electrical conductivity, connect large surface areas of metal parts, remove paint from contact areas.	Good conductivity due to large surface contact.
Ground the control cabinet, the control cabinet door and the mounting plate with ground straps or ground wires. The conductor cross section must be at least 10 mm ² (AWG 8).	Reduces emissions.
Fit switching devices such as power contactors, relays or solenoid valves with interference suppression units or arc suppressors (for example, diodes, varistors, RC circuits).	Reduces mutual interference.
Install power components and control components separately.	
Install frame size 1 and 2 drives on grounded metal back plane.	Reduces emissions.

Shielded cables

EMC measures	Objective
Connect large surface areas of cable shields, use cable clamps and ground straps.	Reduces emissions.
Use cable clamps to connect a large surface area of the shields of all shielded cables to the mounting plate at the control cabinet entry.	
Ground shields of digital signal wires at both ends by connecting them to a large surface area or via conductive connector housings	Reduces interference affecting the signal wires, reduces emissions
Ground the shields of analog signal wires directly at the device (signal input); insulate the shield at the other cable end or ground it via a capacitor (for example, 10 nF, 100 V or higher).	Reduces ground loops due to low-frequency interference.
Use only shielded motor cables with copper braid and a coverage of at least 85%, ground a large surface area of the shield at both ends.	Diverts interference currents in a controlled way, reduces emissions.

Cable Installation

EMC measures	Objective
Do not route fieldbus cables and signal wires in a single cable duct together with lines with DC and AC voltages of more than 60 V. (Fieldbus cables, signal lines and analog lines may be in the same cable duct) Recommendation: Use separate cable ducts at least 20 cm (8 in.) apart.	Reduces mutual interference.
Keep cables as short as possible. Do not install unnecessary cable loops, use short cables from the central grounding point in the control cabinet to the external ground connection.	Reduces capacitive and inductive interference.
Use equipotential bonding conductors in the following cases: wide-area installations, different voltage supplies and installation across several buildings.	Reduces current in the cable shield, reduces emissions.
Use fine stranded equipotential bonding conductors.	Diverts high-frequency interference currents
If motor and machine are not conductively connected, for example by an insulated flange or a connection without surface contact, you must ground the motor with a ground strap or a ground wire. The conductor cross section must be at least 10 mm ² (AWG 8).	Reduces emissions, increases immunity.
Use twisted pair for the DC supply. For digital and analog inputs use shielded twisted cables with a pitch of between 25...50 mm (1...2 in).	Reduces interference affecting the signal cables, reduces emissions.

Power Supply

EMC measures	Objective
Operate product on mains with grounded neutral point.	Enables effectiveness of mains filter.
Surge arrester if there is a risk of overvoltage.	Reduces the risk of damage caused by overvoltage.

Additional measures for EMC improvement

Depending on the application, the following measures can improve the EMC-dependent values:

EMC measures	Objective
Use mains chokes	Reduces mains harmonics, prolongs product service life.
Use external mains filters	Improves the EMC limit values.
Additional EMC measures, for example mounting in a closed control cabinet with 15 dB shielding attenuation of radiated interference	

NOTE: If using an additional input filter, it should be mounted as close as possible to the drive and connected directly to the supply mains via an unshielded cable.

Operation on an IT or Corner Grounded System

Definition

IT system: Isolated or impedance grounded neutral. Use a permanent insulation monitoring device compatible with nonlinear loads, such as an XM200 type or equivalent.

Corner grounded system: System with one phase grounded.

Operation

<i>NOTICE</i>
OVERVOLTAGE OR OVERHEATING If the drive is operated via an IT or corner grounded system, the integrated EMC filter must be disconnected as described in the present manual. Failure to follow these instructions can result in equipment damage.

Disconnecting The Built-in EMC Filter

Filter Disconnection

DANGER

HAZARD OF ELECTRIC SHOCK, EXPLOSION OR ARC FLASH



Read and understand the instructions in **Safety Information** chapter before performing any procedure in this chapter.

Failure to follow these instructions will result in death or serious injury.

The drives have a built-in EMC filter. As a result they exhibit leakage current to ground. If the leakage current creates compatibility problems with your installation (residual current device or other), then you can reduce the leakage current by disconnecting the built-in filter as shown below. In this configuration the product does not meet the EMC requirements according to the standard IEC 61800-3.

Setting

Apply the following instructions to disconnect the built-in EMC filter.

Step	Action
1	Remove the front cover(s) (<i>see page 67</i>)
2	The screw(s) or switch is/are factory set to the  position, as shown on detail ①
3	For operation without the built-in EMC filter, remove the screw(s) from its/ their location or move the switch from its position and set it/them to the  position, as shown on detail ②
4	Refit the front cover(s)

NOTE:

- Use only the screw(s) supplied.
- Do not operate the drive with setting screw(s) removed.

Setting For Frame Size 1 Products

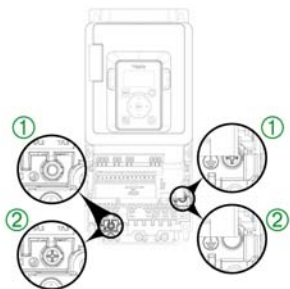

Setting For Frame Size 2 and Frame Size 3 Products

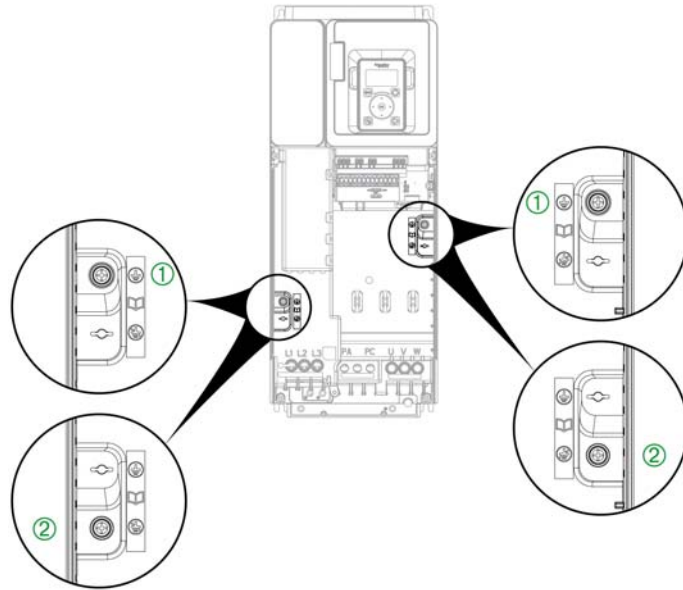

Setting For Frame Size 4 Products

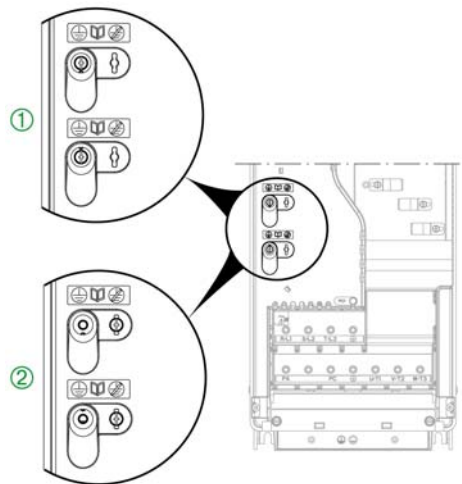

Setting For Frame Size 5 Products

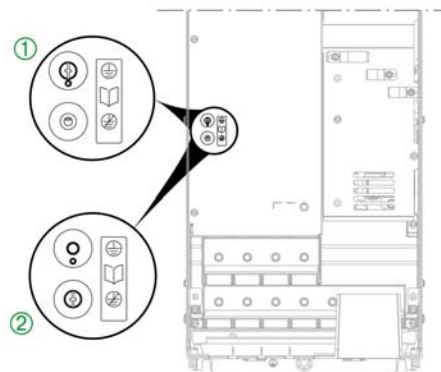

Setting For Frame Size 6 Products

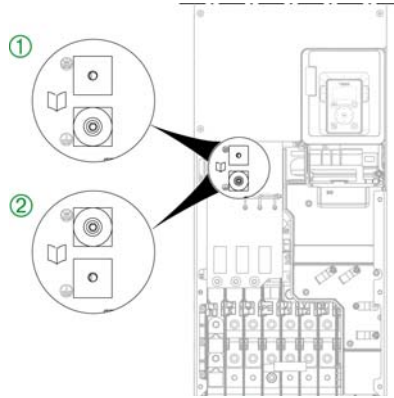

Arrangement and Characteristics of Control Block Terminals and Communication and I/O Ports

Terminal Arrangement

The control block terminals are the same for all drive frame sizes.

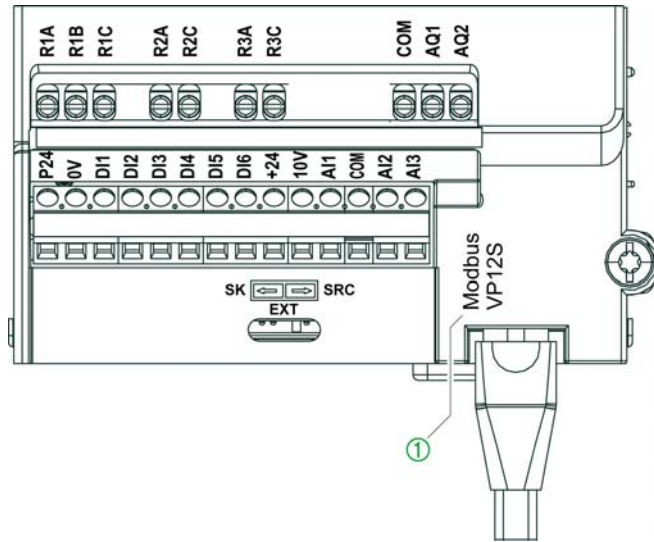

① Modbus VP12S: This is the standard Modbus serial link marking. VP•S means connector with power supply, where 12 stands for the 12 Vdc supply voltage.

Wiring Characteristics

NOTE: Control terminals can accept 1 or 2 wires.

Wire cross sections and tightening torques

Control Terminals	Relay Output Wire Cross Section		Other Wire Cross Section		Tightening Torque
	Minimum (1)	Maximum	Minimum (1)	Maximum	
	mm ² (AWG)	mm ² (AWG)	mm ² (AWG)	mm ² (AWG)	
All terminals	0.75 (18)	1.5 (16)	0.5 (20)	1.5 (16)	0.5 (4.4)

(1) The value corresponds to the minimum permissible cross section of the terminal.

NOTE: Also refer to Control Terminal Electrical data ([see page 78](#)).

RJ45 Communication port

It is used to connect a:

- Remote graphic display terminal, using a Modbus serial line
- Modbus network
- Configuration loader tool...

NOTE: Check that RJ45 cable is not damaged prior to connect it to the product otherwise the power supply of the control could be lost.

Control Terminals Electrical Data

Characteristics of Terminals

NOTE:

- For a description of the terminal arrangement, refer to Arrangement and Characteristics of Control Terminals and Communication And I/O Ports (*see page 77*)
- For factory setting I/O assignment, refer to the Programming manual (*see page 9*).

Terminal	Description	I/O Type	Electrical characteristics
R1A	NO contact of relay R1	O	Output Relay 1 <ul style="list-style-type: none"> • Minimum switching capacity: 5 mA for 24 Vdc • Maximum switching current on resistive load: (cos φ = 1): 3 A for 250 Vac (OVC II) and 30 Vdc • Maximum switching current on inductive load: (cos φ = 0.4 and L/R = 7 ms): 2 A for 250 Vac (OVC II) and 30 Vdc • Refresh time: 5 ms ± 0.5 ms • Service life: 100,000 operations at maximum switching current
R1B	NC contact of relay R1	O	
R1C	Common point contact of relay R1	O	
R2A	NO contact of relay R2	O	Output Relay 2 <ul style="list-style-type: none"> • Minimum switching capacity: 5 mA for 24 Vdc • Maximum switching current on resistive load: 5 A for 250 Vac (OVCII) and 30 Vdc • Maximum switching current on inductive load: 2 A for 250 Vac (OVCII) and 30 Vdc. Inductive load must be equipped with a voltage surge suppression device according to ac or dc operation with total energy dissipation greater than the inductive energy stored in the load. Refer to sections Output Relay with Inductive AC Loads (<i>see page 60</i>) and Output Relay with Inductive DC Loads (<i>see page 61</i>) • Refresh time: 5 ms ± 0.5 ms • Service life: <ul style="list-style-type: none"> ○ 100,000 operations at maximum switching current ○ 1,000,000 operations at 0.5 A
R2C	Common point contact of relay R2	O	
R3A	NO contact of relay R3	O	Output Relay 3 <ul style="list-style-type: none"> • Minimum switching capacity: 5 mA for 24 Vdc • Maximum switching current on resistive load: 5 A for 250 Vac (OVCII) and 30 Vdc • Maximum switching current on inductive load: 2 A for 250 Vac (OVCII) and 30 Vdc. Inductive load must be equipped with a voltage surge suppression device according to ac or dc operation with total energy dissipation greater than the inductive energy stored in the load. Refer to sections Output Relay with Inductive AC Loads (<i>see page 60</i>) and Output Relay with Inductive DC Loads (<i>see page 61</i>) • Refresh time: 5 ms ± 0.5 ms • Service life: <ul style="list-style-type: none"> ○ 100,000 operations at maximum switching current ○ 1,000,000 operations at 0.5 A
R3C	Common point contact of relay R3	O	
24V	Output supply for digital inputs	O	<ul style="list-style-type: none"> • +24 Vdc • Tolerance: minimum 20.4 Vdc, maximum 27 Vdc • Current: maximum 200 mA for both 24 Vdc terminals • Terminal protected against overload and short-circuit • In Sink Ext position, this supply is powered by external PLC supply
COM	Analog I/O common	I/O	0 V for Analog outputs
AQ1	Analog output	O	AQ: Analog output software-configurable for voltage or current <ul style="list-style-type: none"> • Voltage analog output 0...10 Vdc, minimum. Minimum load impedance 470 Ω, • Current analog output X-Y mA by programming X and Y from 0...20 mA, maximum load impedance 500 Ω • Sampling time 10 ms + 1 ms • Resolution 10 bits • Accuracy: ± 1% for a temperature variation of 60°C (140°F) • Linearity ± 0.2%
AQ2	Analog output	O	

Terminal	Description	I/O Type	Electrical characteristics
P24	External input supply	I	External input supply +24 Vdc <ul style="list-style-type: none"> ● Tolerance: minimum 19 Vdc, maximum 30 Vdc ● Current: maximum 0.8 A
0V	0 V	I/O	0 V for P24
DI1-DI6	Digital inputs	I	6 programmable logic inputs 24 Vdc, comply with IEC/EN 61131-2 logic type 1 <ul style="list-style-type: none"> ● Positive logic (Source): State 0 if ≤ 5 Vdc or logic input not wired, state 1 if ≥ 11 Vdc ● Negative logic (Sink): State 0 if ≥ 16 Vdc or logic input not wired, state 1 if ≤ 10 Vdc ● Impedance 3.5 kΩ ● Maximum voltage: 30 Vdc ● Sampling time: 2 ms + 0.5 ms maximum <p>Multiple assignment makes it possible to configure several functions on one input (example: DI1 assigned to forward and preset speed 2, DI3 assigned to reverse and preset speed 3).</p>
DI5-DI6	Pulse inputs	I	Programmable Pulse input <ul style="list-style-type: none"> ● Comply with level 1 PLC, IEC 65A-68 standard ● State 0 if < 0.6 Vdc, state 1 if > 2.5 Vdc ● Pulse counter 0...30 kHz ● Frequency range: 0...30 kHz ● Cyclic ratio: 50 % \pm 10 % ● Maximum input voltage 30 Vdc, < 10 mA ● Sampling time: 5 ms + 1 ms maximum
10V	Output supply for Analog input	O	Internal supply for the analog inputs <ul style="list-style-type: none"> ● 10.5 Vdc ● Tolerance \pm 5% ● Current: maximum 10 mA ● Short circuit protected
AI1-AI2-AI3	Analog inputs	I	Software-configurable V/A : voltage or current analog input <ul style="list-style-type: none"> ● Voltage analog input 0...10 Vdc, impedance 30 kΩ, ● Current analog input X-Y mA by programming X and Y from 0...20 mA, with impedance 250 Ω ● Sampling time: 5 ms + 1 ms maximum ● Resolution 12 bits ● Accuracy: \pm 0.6% for a temperature variation of 60°C (140°F) ● Linearity \pm 0.15% of maximum value
COM	Analog I/O common	I/O	0 V for Analog inputs

Terminal	Description	I/O Type	Electrical characteristics
AI2-AI3	Sensor inputs	I	<p>Software-configurable PT100/PT1000 or KTY84 or PTC or Water level sensor</p> <ul style="list-style-type: none"> ● PT100 <ul style="list-style-type: none"> ○ 1 or 3 thermal sensors mounted in series (configurable by software) ○ Sensor current: 5 mA ○ Range -20...200°C (-4...392°F) ○ Accuracy ± 4°C (39°F) for a temperature variation of 60°C (140°F) ● PT1000 <ul style="list-style-type: none"> ○ 1 or 3 thermal sensors mounted in series (configurable by software) ○ Thermal sensor current: 1 mA ○ Range -20...200°C (-4...392°F) ○ Accuracy ± 4°C (39°F) for a temperature variation of 60°C (140°F) ● PTC <ul style="list-style-type: none"> ○ 6 sensors maximum mounted in series ○ Sensor current: 1 mA ○ Nominal value: < 1.5 kΩ ○ Overheat trigger threshold: 2.9 kΩ ± 0.2 kΩ ○ Overheat reset threshold: 1.575 kΩ ± 0.75 kΩ ○ Low impedance detection threshold: 50 Ω -10 Ω/+20 Ω ● KTY84 <ul style="list-style-type: none"> ○ 1 thermal sensor ○ Thermal sensor current: 1 mA ○ Range -20...200°C (-4...392°F) ○ Accuracy ± 4°C (39°F) for a temperature variation of 60°C (140°F) ● Water Level Sensor <ul style="list-style-type: none"> ○ Sensitivity: 0...1 MΩ, adjustable by software ○ Water level sensor current: 0.3 mA...1 mA maximum ○ Adjustable delay: 0...10 s

Wiring The Control Part

Preliminary Steps

 DANGER
HAZARD OF ELECTRIC SHOCK, EXPLOSION OR ARC FLASH Read and understand the instructions in Safety Information chapter before performing any procedure in this chapter. Failure to follow these instructions will result in death or serious injury.

 WARNING
UNINTENDED BEHAVIOR OF INPUTS AND OUTPUTS The functions of the inputs and outputs depend on the selected operating mode and the settings of the corresponding parameters. <ul style="list-style-type: none">• Verify that the wiring is appropriate for the settings.• Only start the system if there are no persons or obstructions in the hazardous area.• When commissioning, carefully run tests for all operating states and potential error situations. Failure to follow these instructions can result in death, serious injury, or equipment damage.

Access to the Terminals

 DANGER
HAZARD OF ELECTRIC SHOCK, EXPLOSION OR ARC FLASH Read and understand the instructions in Safety Information chapter before performing any procedure in this chapter. Failure to follow these instructions will result in death or serious injury.

To access the control terminals, refer to the procedure described in the Wiring the Power Part chapter ([see page 67](#)).

Optional Module Installation and Wiring

To help ensure correct wiring of the control part, apply the following instructions to install and connect a module to be wired

Step	Action
1	Insert the module in the dedicated slot.
2	Connect the cable to the module

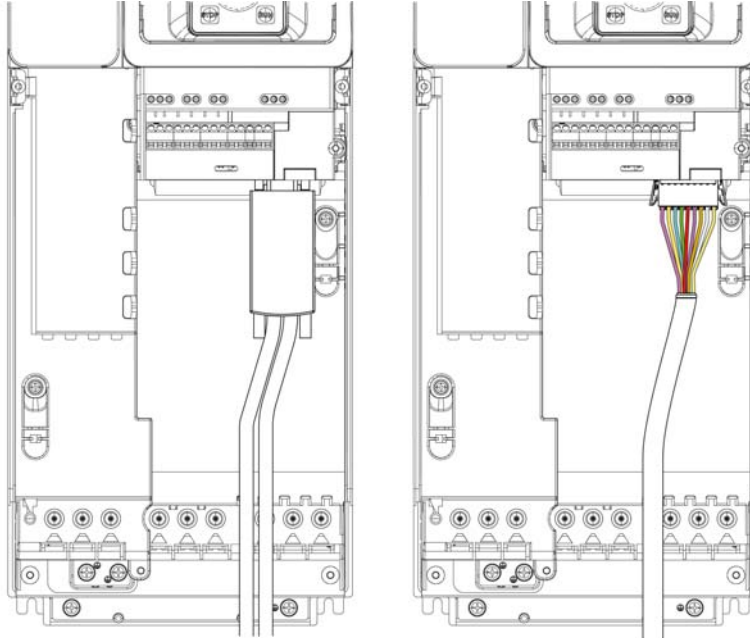

I/O Relay Module Installation and Wiring

To help ensure correct wiring of the control part, apply the following instructions to install and connect an I/O relay module.

Step	Action
1	Insert the I/O relay module in the option module slot.
2	Push the module into its location and keep access to the module terminal screws.
3	Prepare the I/O cable for wiring.
4	Wire the I/O relay module.
5	Push again the module to its final position.

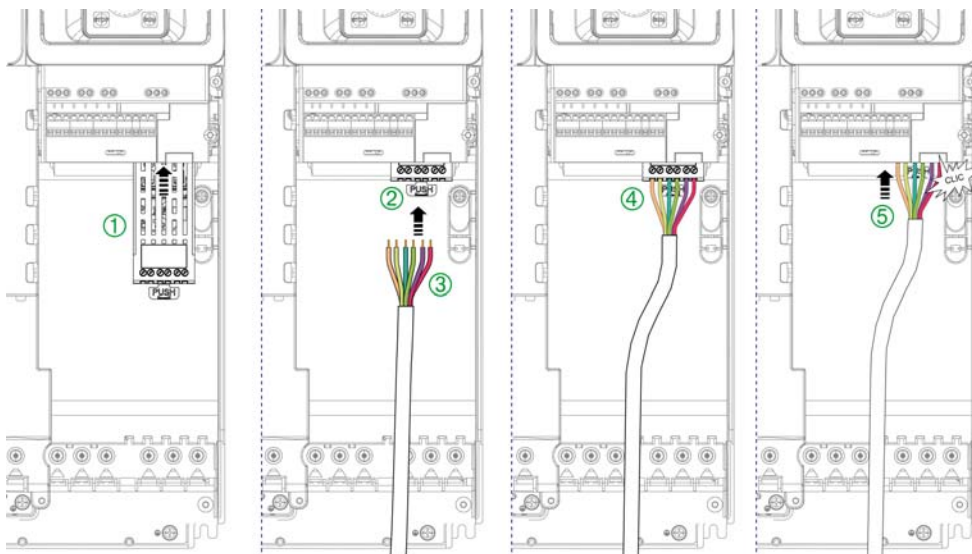

Control Cables Path - Drives With Conduit Box

To help ensure correct wiring of the control part, apply the following instructions to wire the control block terminals

Step	Action
1	Wire the P24, 0V, the digital inputs (DI1...DI6), and the +24 terminals
2	Wire the COM and the analog outputs (AQ1, AQ2) terminals, wire the 10V, the analog inputs (AI1...AI3) and COM terminals
3	Wire the Relay outputs

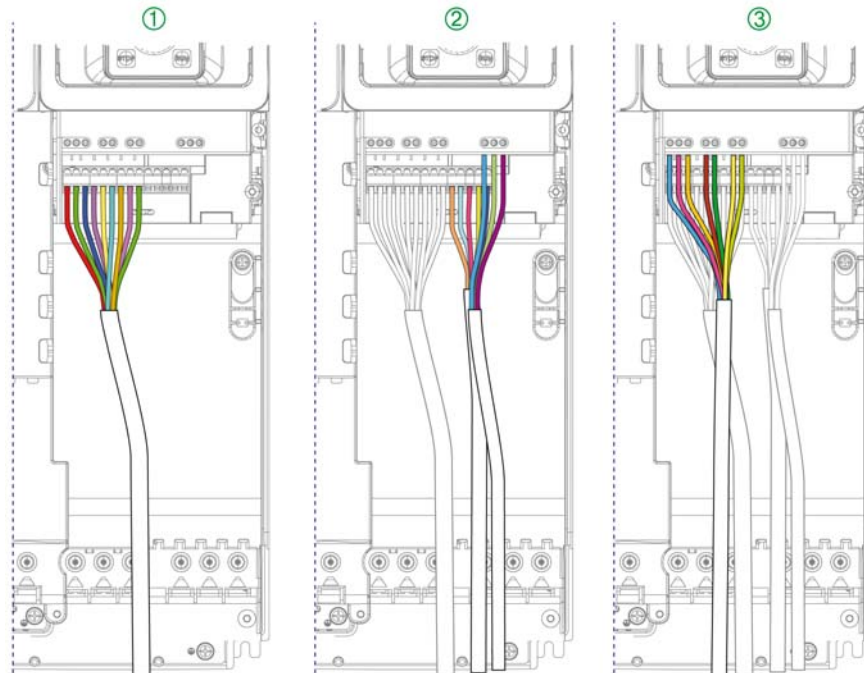

Chapter 5

Checking Installation

Check List Before Switching On

Unsuitable settings or unsuitable data or unsuitable wiring may trigger unintended movements, trigger signals, damage parts and disable monitoring functions.

 WARNING
UNANTICIPATED EQUIPMENT OPERATION <ul style="list-style-type: none">• Only start the system if there are no persons or obstructions in the zone of operation.• Verify that a functioning emergency stop push-button is within reach of all persons involved in the operation.• Do not operate the drive system with unknown settings or data.• Verify that the wiring is appropriate for the settings.• Never modify a parameter unless you fully understand the parameter and all effects of the modification.• When commissioning, carefully run tests for all operating states, operating conditions and potential error situations.• Anticipate movements in unintended directions or oscillation of the motor. Failure to follow these instructions can result in death, serious injury, or equipment damage.

If the power stage is disabled unintentionally, for example as a result of power outage, errors or functions, there is a possibility that the motor is no longer decelerated in a controlled way.

 WARNING
UNANTICIPATED EQUIPMENT OPERATION <p>Verify that movements without braking effect cannot cause injuries or equipment damage.</p> Failure to follow these instructions can result in death, serious injury, or equipment damage.

Mechanical Installation

Verify the mechanical installation of the entire drive system:

Step	Action	✓
1	Does the installation meet the specified distance requirements?	
2	Did you tighten all fastening screws to the specified tightening torque?	

Electrical installation

Verify the electrical connections and the cabling:

Step	Action	✓
1	Did you connect all protective ground conductors?	
2	The correct tightening of the screws may be altered during assembly and wiring phases of the drive. Verify and adjust the tightening of all terminal screws to the specified nominal torque.	
3	Do all fuses and circuit breaker have the correct rating; are the fuses of the specified type? (refer to the catalog).	
4	Did you connect or insulate all wires at the cable ends?	
5	Did you properly connect and install all cables and connectors?	
6	Do all plug-in terminals colors and markings correspond to the colors and marking of the control block?	
7	Did you properly connect the signal wires?	
8	Are the required shield connections EMC-compliant?	
9	Did you take all measures for EMC compliance?	

Covers And Seals

Verify that all devices, doors and covers of cabinet are properly installed to meet the required degree of protection.

Chapter 6

Maintenance

What Is in This Chapter?

This chapter contains the following topics:

Topic	Page
Scheduled Servicing	87
Long-term Storage	89
Decommissioning	89
Additional Support	89

Scheduled Servicing

Servicing

DANGER

HAZARD OF ELECTRIC SHOCK, EXPLOSION OR ARC FLASH

Read and understand the instructions in **Safety Information** chapter before performing any procedure in this chapter.

Failure to follow these instructions will result in death or serious injury.

The temperature of the products described in this manual may exceed 80 °C (176 °F) during operation.

WARNING

HOT SURFACES

- Ensure that any contact with hot surfaces is avoided.
- Do not allow flammable or heat-sensitive parts in the immediate vicinity of hot surfaces.
- Verify that the product has sufficiently cooled down before handling it.
- Verify that the heat dissipation is sufficient by performing a test run under maximum load conditions.

Failure to follow these instructions can result in death, serious injury, or equipment damage.

WARNING

INSUFFICIENT MAINTENANCE

Verify that the maintenance activities described below are performed at the specified intervals.

Failure to follow these instructions can result in death, serious injury, or equipment damage.

Adherence to the environmental conditions must be ensured during operation of the drive. In addition, during maintenance, verify and, if appropriate, correct all factors that may have an impact on the environmental conditions.

	Part concerned	Activity	Interval (1)
Overall condition	All parts such as housing, HMI, control block, connections, etc.	Perform a visual inspection	At least every year
Corrosion	Terminals, connectors, screws	Inspect and clean if required	
Dust	Terminals, fans, cabinet air inlets and air outlets, air filters of cabinet	Inspect and clean if required	
Cooling	Fan	Verify the fan operation	At least every year
Fastening	All screws for electrical and mechanical connections	Verify tightening torques	At least every year
(1) Maximum maintenance intervals from the date of commissioning. Reduce the intervals between maintenance to adapt maintenance to the environmental conditions, the operating conditions of the drive, and to any other factor that may influence the operation and/ or maintenance requirements of the drive.			

NOTE: The fan operation depends on the drive thermal state. The drive may be running and the fan not. Fans may continue to run for a certain period of time even after power to the product has been disconnected.

 CAUTION
RUNNING FANS
Verify that fans have come to a complete standstill before handling them.
Failure to follow these instructions can result in injury or equipment damage.

Diagnostic And Troubleshooting

Refer to the ATV610 Programming Manual (*see page 9*) available on www.schneider-electric.com.

Spares and repairs

Serviceable product. Please refer to your Customer Care Center on:

www.schneider-electric.com/CCC.

Long-term Storage

Capacitor Reforming

If the drive was not connected to mains for an extended period of time, the capacitors must be restored to their full performance before the motor is started.

NOTICE

REDUCED CAPACITOR PERFORMANCE

- Apply mains voltage to the drive for one hour before starting the motor if the drive has not been connected to mains for the following periods of time:
 - 12 months at a maximum storage temperature of +50°C (+122°F)
 - 24 months at a maximum storage temperature of +45°C (+113°F)
 - 36 months at a maximum storage temperature of +40°C (+104°F)
- Verify that no Run command can be applied before the period of one hour has elapsed.
- Verify the date of manufacture if the drive is commissioned for the first time and run the specified procedure if the date of manufacture is more than 12 months in the past.

Failure to follow these instructions can result in equipment damage.

If the specified procedure cannot be performed without a Run command because of internal mains contactor control, perform this procedure with the power stage enabled, but the motor being at standstill so that there is no appreciable mains current in the capacitors.

Decommissioning

Uninstall the Product

Observe the following procedure when uninstalling the product.

- Switch off all supply voltage. Verify that no voltages are present - refer to Safety Information chapter (*see page 5*).
- Remove all connection cables.
- Uninstall the product.

End of Life

The components of the product consist of different materials which can be recycled and which must be disposed of separately.

- Dispose of the packaging in compliance with all applicable regulations.
- Dispose of the product in compliance with all applicable regulations.

Refer to Green Premium section (*see page 16*) for information and documents on environmental protection such as EoLI (End of Life instruction).

Additional Support

Customer Care Center

For additional support, you can contact our Customer Care Center on:

www.schneider-electric.com/CCC.



A

AC

Alternating Current

D

DC

Direct Current

E

ELV

Extra-Low Voltage. For more information: IEC 60449

Error

Discrepancy between a detected (computed, measured, or signaled) value or condition and the specified or theoretically correct value or condition.

F

Factory setting

Factory settings when the product is shipped

Fault

Fault is an operating state. If the monitoring functions detect an error, a transition to this operating state is triggered, depending on the error class. A "Fault reset" is required to exit this operating state after the cause of the detected error has been removed. Further information can be found in the pertinent standards such as IEC 61800-7, ODVA Common Industrial Protocol (CIP).

Fault reset

A function used to restore the drive to an operational state after a detected error is cleared by removing the cause of the error so that the error is no longer active.

G

GP

General-Purpose

L

L/R

Time constant equal to the quotient of inductance value (L) over the resistance value (R).

N

NC contact

Normally Closed contact

NO contact

Normally Open contact

O

OEM

Original Equipment Manufacturer

OVCII

Overvoltage Category II, according IEC 61800-5-1

P**PA/+**

DC bus terminal

PC/-

DC bus terminal

PELV

Protective Extra Low Voltage, low voltage with isolation. For more information: IEC 60364-4-41

PLC

Programmable logic controller

Power stage

The power stage controls the motor. The power stage generates current for controlling the motor.

PTC

Positive Temperature Coefficient. PTC thermistor probes integrated in the motor to measure its temperature

R**REACH**

Registration, Evaluation, Authorisation and restriction of Chemicals regulation

RoHS

Restriction of Hazardous Substances

S**SCPD**

Short-Circuit Protective Device

STO

Safe Torque Off: No power that could cause torque or force is supplied to the motor

T**TVS Diode**

Transient Voltage Suppression Diode

V**VHP**

Very High Horse Power (> 800 kW)

W**Warning**

If the term is used outside the context of safety instructions, a warning alerts to a potential problem that was detected by a monitoring function. A warning does not cause a transition of the operating state.

<https://sid1.hu/>

